

SIGN & DISPLAY

COLLECTION

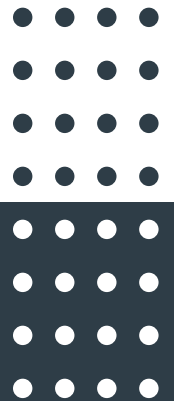

Issue 2



REINVENTING URBAN
LOGISTICS
THROUGH POWERFUL
TECHNOLOGY

parcelly



Welcome

- Market leading designs for every area of promotional signage and display.
- Excellent value for maximum return on investment.
- Used by leading brands and retailers throughout the UK and around the world.
- Many unique features and benefits.
- Huge stocks and fast delivery.
- Majority of products available with no minimum order quantity and no small quantity surcharge.
- Custom colours and sizes available on many lines.
- High quality print service available.



Contents

Page
4 - 67

Outdoor (Indoor) **Free-Standing/Floor Mounted**

- Pavement and Forecourt Signs for displaying short/medium term interchangeable posters – includes Swinger and Sentinel®
- Pavement and Forecourt Signs for medium/longer term printed panels – includes Ecoflex, Swinger and POW!
- Pavement and Forecourt Signs for chalk or chalk pen messaging
- Banner Frames and Bollard Wraps
- Flying Banners – Feather, Teardrop and Rectangle Flags
- Adfresco® Café Barriers
- Parasols
- Signtac® Floor Graphics

Page
68 - 99

Outdoor (Indoor) **Wall/Window Mounted**

- Dealer/Stockist Signs
- Poster Frames – Snapframes, Slimlok and Hi-Sight
- Illuminated Poster Frames
- Noticeboards and Menu Cases
- Banners and Banner Frames
- Projecting Flange Signs
- Display Flags and Noscrewz window suction bracket
- Information Displays – poster and leaflet combinations
- Chalkboards
- Leaflet Holders
- Stickers, Labels and Window Graphics
- Stand-Off Sign Fixings

Page
100 - 137

Indoor **Free-Standing/Floor Mounted**

- Pole & Rope Barriers
- Easels – for chalkboards and Snapframes
- Poster/Menu Stands
- Showcard Stands/‘Bus Stop’ Signs
- Flying Banners with Base Plate
- Roll-Ups and Banner Displays
- Pop-Ups – portable exhibition backdrops
- Promotional Counters
- Modular Pole Display – brochure, poster and banner combinations
- Brochure Stands
- Dump Bins
- Promotional Floor Mats
- Basket Liner

Page
138 - 157

Indoor
Wall/Window Mounted

- Open/Closed Signs
- Poster Frames – Headliner and Minimus Snapframe
- Illuminated Poster Frames
- Chalkboards
- Sign Nav – wayfinding display/sign system
- Brochure and Leaflet Displays

Page
158 - 167

Indoor
Suspended/Hanging

- Poster/Banner Rails
- Snapframes
- Freelight Plus – uses existing in-store lighting
- Mobiles
- Magnetic POS Flag Arm/aisle flag holder
- Chalkboards

Page
168 - 187

Indoor
Counter/Table/Shelf

- Menu and Poster Holders
- Table Talkers
- Leaflet Dispensers
- Chalkboards
- Display Card/Ticket Holders
- Bar Runners and Counter Mats
- Brand Blocks
- Dump Bins
- Shelf/Display Wobblers
- Ice Cream Holders and Cup Displays

Page
188 - 197

Print

- Service and Capabilities
- Posters
- Backlit Poster Films – ‘Duratrans’
- Print Product Overview

Page
198 - 203

**Accessories
& Spares**

Key



In Stock



No Tools Assembly



Made To Order



Recyclable



Illuminated

FUEL REWARDS EVERY 10 VISITS*

SAY HELLO TO REWARDS

GOOD THINGS HAPPEN WHEN YOU GO+ IT

SURPRISE FREEBIES

Download the Shell app today

GO WELL

*A visit with a minimum spend of £10 on fuel or £2 on products from the shop (excluding lottery tickets, alcoholic beverages, tobacco, phone cards and any other age restricted products) is counted towards a fuel reward (in qualifying purchases) at selected Shell Service Stations. For more information see goplus.shell.com

Outdoor (Indoor) Free-Standing/Floor Mounted

Experts in this field, we manufacture a market leading range of outdoor portable signs and displays.

Some of these can be large and heavy, so design is critical. Often used in busy pedestrianised areas, in close proximity to parked vehicles or on the kerbside close to passing traffic, safety and reliability is imperative. At the same time they need to be easy to move, in and out of store on a daily basis if required, and poster graphics where applicable must be simple and quick to update. Other than occasional extremes they need to withstand the best and worst of the British weather, year in, year out.

Outdoor free-standing signage, in the retail, service and hospitality sectors in particular, is a powerful tool in the drive to increase market share and sales. With measurable return on investment, top brands and retailers use them widely and consistently to influence consumer decisions and drive footfall. Tactical and multi-functional they can act as a 'signpost' to your business whilst clearly communicating you are open for business. They can be particularly effective at influencing the impulse shopper.

Swinger

Patent No. 2437991 & 2464773
UK Design Registration No. 2071096
EU Design Registration No. 001274229

Why is Swinger the UK's market leading pavement sign?

- Beautifully designed and engineered.
- Low centre of gravity for maximum stability.
- Quick and easy no tools assembly.
- Individually boxed and flat packed with instructions.
- Soft round styling for high pedestrian safety.
- Fully recyclable.



- Optional clip-on Tactical Header (see page 12).
- Patented D-Flex panel hangers allow for easy no tools panel fitting. Flexibility and low friction ensures panel performance.
- Stylish steel frame available in black or white from stock, can also be powder coated in any RAL colour (minimum order quantity 25).
- Choice of aluminium panel or top-opening magnetic poster pocket (shown).
- Solid recycled PVC (shown) or water fillable HDPE polyethylene base options.



No Tools Assembly

- Simply push base onto frame.

OR



- For Swinger 2 simply lift frame through 90 degrees, straight from the box.



Built-In Wheels

- For ease of movement on heavier Swinger 3000 and 4000 models.



D-Flex Panel Hangers

- Friction-free panel movement.
- Unique design absorbs impact and protects the panel.



Hard-Wearing 'Black' Bases

- Solid recycled PVC on Eco Swinger and Swinger 2.
- Water-fillable polyethylene on Swinger 3000 and 4000 (shown).



Tactical Header

- Clip-on header available on all models.

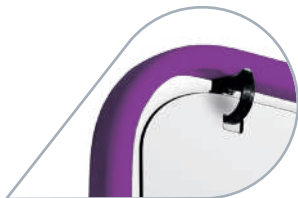

Powder Coated Steel Frames

- White and black stock options on all models.
- Other colours available to order (minimum order quantity 25).



Top Opening Poster Pockets

- Easy access poster change.
- Self closing magnetic seals provide excellent weather protection.
- Virtually no risk of poster loss.



The Swinger Family

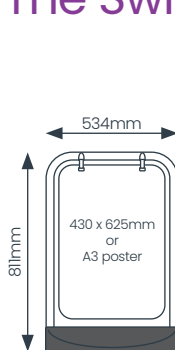

Eco Swinger

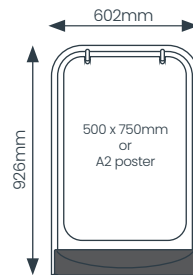

Swinger 2

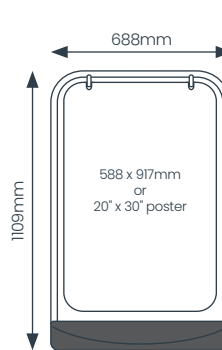

Swinger 3000

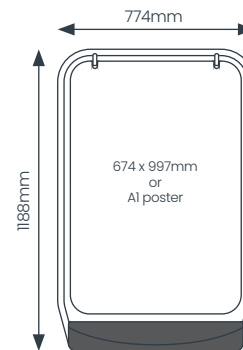

Swinger 4000

Eco Swinger

The smallest Swinger in our range.

Instruction Video



- Gloss white aluminium panel (430 x 625 x 0.9mm) – ideal for direct to surface print or vinyl graphics.
- Alternative top opening polycarbonate double sided A3 poster pocket with magnetic seals.
- Poster pocket designed with header area for permanent branding – ideal for either direct to surface print or vinyl graphics.
- Stylish 32mm round steel tube frame – available in black or white from stock.
- Frames available in any RAL colour (minimum order quantity 25).
- Patented D-Flex panel hangers make panel fitting quick and easy.
- Solid black recycled PVC base provides excellent stability.
- Clip-on Tactical Headers also available, giving extra promotional space at minimal cost (see page 12).



Easy access top-opening poster pocket.



Effortless no tools assembly.



Fully Recyclable

Display Type	Display Area (mm)	O/A Dimensions (w x h x d mm)	Weight (kg)	Frame Colour	Poster Pocket Colour	Order Code
Aluminium Panel	430 x 625	534 x 811 x 490	11	White	-	SWIECOW
				Black	-	SWIECOB
Poster Pocket	281 x 403 (A3)	534 x 811 x 490	11	White	White	ECOSWPSTW
				Black	Black	ECOSWPSTB



Poster Option

Swinger 2

Our top selling Swinger model.

Patent No. 2549613
Instruction Video

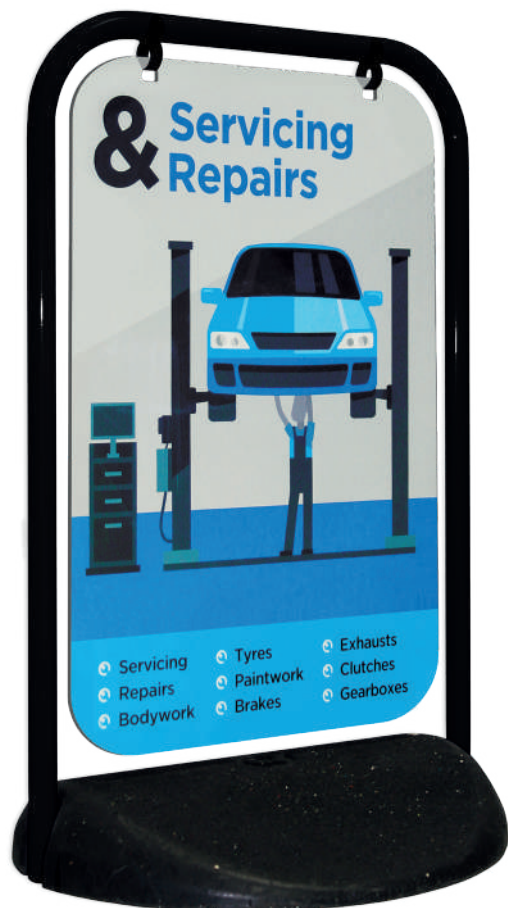

- Gloss white aluminium panel (500 x 750 x 0.9mm) – ideal for direct to surface print or vinyl graphics.
- Alternative top opening polycarbonate double sided A2 poster pocket with magnetic seals.
- Poster pocket designed with header area for permanent branding – ideal for either direct to surface print or vinyl graphics.
- Stylish steel tube frame (32mm diameter) – available in black or white from stock.
- Frames available in any RAL colour (minimum order quantity 25).
- Patented D-Flex panel hangers make panel fitting quick and easy.
- Solid black recycled PVC base provides excellent stability.
- Clip-on Tactical Headers also available, giving extra promotional space at minimal cost (see page 12).



Simply lift frame through 90 degrees.



Easy access top-opening poster pocket.



Fully Recyclable

Display Type	Display Area (mm)	O/A Dimensions (w x h x d mm)	Weight (kg)	Frame Colour	Poster Pocket Colour	Order Code
Aluminium Panel	500 x 750	602 x 926 x 525	13.5	White	-	SWING2ALIW
				Black	-	SWING2ALIB
Poster Pocket	400 x 575 (A2)	602 x 926 x 525	13.5	White	White	SWING2PSTW
				Black	Black	SWING2PSTB



Poster Option

Swinger 3000

A larger Swinger with wheels.

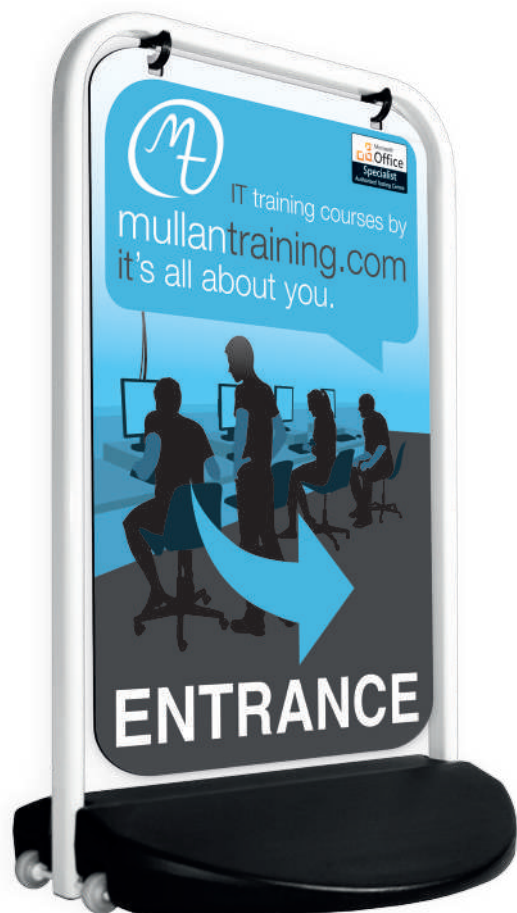

- Gloss white aluminium panel (588 x 917 x 0.9mm) – ideal for direct to surface print or vinyl graphics.
- Alternative top opening polycarbonate double sided 20" x 30" poster pocket with magnetic seals.
- Poster pocket designed with header area for permanent branding – ideal for either direct to surface print or vinyl graphics.
- Flat sided oval steel tube frame (50 x 25mm) – available in black or white from stock.
- Frames available in any RAL colour (minimum order quantity 25).
- Patented D-Flex panel hangers make panel fitting quick and easy.
- Black water-fillable polyethylene base for optimum stability, also available in any RAL colour (minimum order quantity 200).
- Built-in wheels for ease of movement.
- Clip-on Tactical Headers also available, giving extra promotional space at minimal cost (see page 12).



Easy access top-opening poster pocket.



Effortless no tools assembly.

   Fully Recyclable

Display Type	Display Area (mm)	O/A Dimensions (w x h x d mm)	Weight (kg) Empty/Full	Frame Colour	Poster Pocket Colour	Order Code
Aluminium Panel	588 x 917	688 x 1109 x 600	12/31	White	-	H3000BWWA
				Black	-	H3000BBWA
Poster Pocket	488 x 742 (20" x 30")	688 x 1109 x 600	12/31	White	White	SW3KPSTW
				Black	Black	SW3KPSTB



Poster Option

Swinger 4000

Pack a punch with our largest standard Swinger.

Instruction Video



- Gloss white aluminium panel (674 x 997 x 0.9mm) – ideal for direct to surface print or vinyl graphics.
- Alternative top opening polycarbonate double sided A1 poster pocket with magnetic seals.
- Poster pocket designed with header area for permanent branding – ideal for either direct to surface print or vinyl graphics.
- Standard or custom shaped panels available (within 674 x 997mm).
- Stylish oval steel tube frame (50 x 25mm) – available in black or white from stock.
- Frames available in any RAL colour (minimum order quantity 25).
- Patented D-Flex panel hangers make panel fitting quick and easy.
- Black water-fillable polyethylene base for optimum stability, also available in any RAL colour (minimum order quantity 200).
- Built-in wheels for ease of movement.
- Clip-on Tactical Headers also available giving extra promotional space at minimal cost (see page 12).



Easy access top-opening poster pocket.



Effortless no tools assembly.



Fully Recyclable

Display Type	Display Area (mm)	O/A Dimensions (w x h x d mm)	Weight (kg) Empty/Full	Frame Colour	Poster Pocket Colour	Order Code
Aluminium Panel	674 x 997	774 x 1188 x 600	14/32	White	-	SW4KALIW
				Black	-	SW4KALIB
Poster Pocket	574 x 822 (A1)	774 x 1188 x 600	14/32	White	White	SW4KPSTW
				Black	Black	SW4KPSTB



Poster Option

Swinger Tactical Header

Be reactive with our clip-on Swinger header.



Fully Recyclable

- No tools clip-on design. A variant to suit every Swinger model.
- Ideal for short term or dual brand promotions - additional advertising space at a minimal cost.
- 0.9mm rigid gloss white PVC panel ideal for screen/ digital print or vinyl graphics.
- Supplied complete with clips.
- Custom shapes available made to order (minimum order quantity 25).
- Poster pocket option also available made to order (minimum order quantity 10).

Type	Size (mm)	Order Code
Eco Swinger	480 x 178	THECO
Swinger 2	542 x 197	THSWING2
Swinger 3000	629 x 231	TH3000
Swinger 4000	716 x 230	TH4000



Poster pocket headers



Custom shaped headers

A-Master

With front opening snapframe.



- Double sided poster display in a wide range of sizes.
- Front opening 32mm profile aluminium snapframes with rounded corners for safety.
- Anti-glare poster cover sheets are UV stable and filter sunlight to protect poster colours.
- Galvanised steel back panels and hinged locking arms for optimum weight and stability.
- Back panel suitable for vinyl application enabling messaging between poster promotions.
- Fold flat design – easy to move and store.
- Stock sizes available in a choice of silver anodised and black powder coated finish.
- Custom colours available made to order (minimum order quantity 25).
- Optional chalk insert panels available (see page 41).



Fully Recyclable



Rounded corners for style and safety.



Front opening snapframes for quick and easy poster change.

Poster Size	Display Area (mm)	O/A Dimensions (w x h x d mm)	Leg Length (mm)	Weight (kg)	Availability	Finish	Order Code
A2	400 x 574	463 x 910 x 700	950	4.5	In stock	Silver	ABA2GR(W)
						Black	ABA2BR(W)
20" x 30"	488 x 742	551 x 910 x 700	950	6	In stock	Silver	AB23GR(W)
						Black	AB23BR(W)
A1	574 x 821	637 x 1100 x 800	1150	7.5	In stock	Silver	ABA1GR(W)
						Black	ABA1BR(W)
30" x 40"	742 x 996	805 x 1200 x 850	1250	11.5	Made to order	Silver	AB34GR(M)
A0	821 x 1169	884 x 1400 x 910	1450	16.5	In stock	Silver	ABA0GR(W)

A-Master Lite

Lighter in weight, lighter in price.



- Double sided poster display for popular A2 and A1 poster sizes.
- Front opening 25mm profile aluminium snapframes for quick and easy poster change.
- Round corners for pedestrian safety.
- Anti-glare poster cover sheets are UV stable and filter sunlight to protect poster colours.
- Available in hard-wearing satin black or silver anodised finish.
- Smooth galvanized steel back panel suitable for vinyl application, allowing messaging between poster promotions.
- Fold-flat design - easy to move and store.
- Optional chalk insert panels available (see page 41).

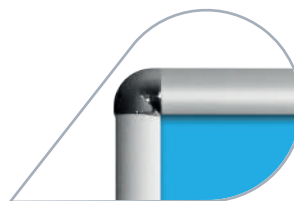

25mm profile
snapframe.



Rounded corners
for safety.



Fully Recyclable

Poster Size	Display Area (mm)	O/A Dimensions (w x h x d mm)	Weight (kg)	Frame Colour	Order Code
A2	400 x 574	450 x 852 x 540	2.75	Silver	ABA2SLITE
			2.9	Black	ABA2BLITE
A1	574 x 821	620 x 1160 x 610	4.55	Silver	ABA1SLITE
			4.7	Black	ABA1BLITE

A-Master Plus

Extended A1 poster display, with extra snapframe header.



- Double sided A1 poster display in silver anodised finish.
- Snapframe header for 594 x 176mm insert, suitable for vinyl application.
- Front opening 32mm profile aluminium snapframes with rounded corners for safety.
- Galvanised steel back panels and hinged locking arms for optimum weight and stability.
- Anti-glare poster cover sheets are UV stable and filter sunlight to protect poster colours.
- Fold flat design – easy to move and store.
- Recommended for indoor or sheltered outdoor locations.
- Custom colours available made to order (minimum order quantity 25).
- Optional chalk insert panels available (see page 41).



Extra snapframe header.



Front opening snapframes for quick and easy poster change.

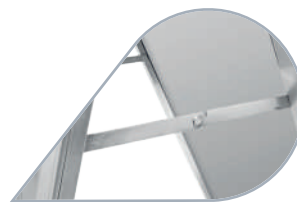

Locking side arms ensure stability.



Fully Recyclable

Poster Size	Display Area (w x h mm)	Dimensions (mm)	Weight (kg)	Order Code
A1	Poster: 574 x 821 Header: 574 x 156	O/A: 640 x 1112 x 807 Poster: 594 x 841 Header: 594 x 176	10.6	ABA1PLUS

Informer

Double sided display with hidden poster change mechanics.



- Double sided 20" x 30" poster display.
- Anti-glare PET poster covers with magnetic seals offer excellent poster security and weather resistance.
- Poster release: simply push poster cover out of frame via hidden release hole in back panel.
- White polyester powder coated steel frame as standard.
- Custom colours available made to order (minimum order quantity 200).
- Colour matched white printed borders to poster covers.
- Folds flat for storage.
- Optional chalk insert panels available (see page 41).



Magnetic sealed poster covers.



Hidden poster cover release hole in back panel.



Hinged side locking arm.



Moulded feet.



Fully Recyclable

Poster Size	Display Area (mm)	O/A Dimensions (w x h x d mm)	Weight (kg)	Order Code
20" x 30"	505 x 759	570 x 890 x 550	12	IN230W(W)

Booster

Attractive poster A-Board with semi-circular header.

Make-to-order stock RAL colours:

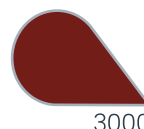
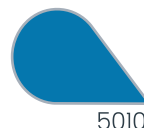

- Double sided with additional header area – ideal for vinyl application.
- Anti-glare PET poster covers, with magnetic seals and colour matched borders, provide excellent poster security and weather resistance.
- Poster release: simply push poster cover out of frame via hidden release hole in back panel.
- Steel tube frame (25mm diameter) and steel back panels – available in black or white from stock.
- Seven make-to-order stock colours available (no minimum order quantity).
- Other custom colours available (minimum order quantity 50).



Magnetic poster covers – simply push out via hidden release hole.



Locking side arms ensure stability.



Fully Recyclable

Poster Size	Display Area (mm)	O/A Dimensions (w x h x d mm)	Header Area (w x h mm)	Weight (kg)	Colour	Order Code
A2	Poster: 418 x 592 Header: 410 x 230	500 x 1065 x 700	410 x 230	11.2	White	BRA2W
					Black	BRA2BL
20" x 30"	Poster: 506 x 760 Header: 498 x 274	588 x 1220 x 850	498 x 274	15.4	White	BR23W
					Black	BR23BL
A1	Poster: 592 x 839 Header: 590 x 320	674 x 1410 x 900	590 x 320	18.8	White	BRA1W
					Black	BRA1BL



Turn your Booster into a Chalk A-Board with Chalk Insert Panels.
(for more information see page 41).

Sightmaster 3

Stylish spring mounted snapframe sign with advanced performance features.



- Available in two colour options with advanced style, stability and performance.
- Front opening aluminium snapframes for quick and easy poster change. Opening tool supplied for easy access.
- High strength Aluminium Composite Material back panel has smooth white surfaces for self adhesive vinyl graphics or liquid chalkpen messaging if posters are not in use.
- Unique water-fillable HDPE base with built-in wheels.
- Heavy duty spring mounts ensure stability by allowing panel deflection in the wind.
- Anti-glare poster cover sheets ensure clarity and vibrancy by protecting posters from UV fade.
- Soft round corners for safety.
- Transit trolley available to aid movement when base is full (30" x 40" and A0 sizes only).
- Ideal for forecourts, entrance approaches, car parks, retail outlets and shopping centres.
- Supplied with 2 piece spanner set.



Large base designed for use with our transit trolley (see page 40 for details).



Nylon feet reduce wear and increase stability on uneven surfaces.



Exclusive design base has optimised water capacity for advanced stability.

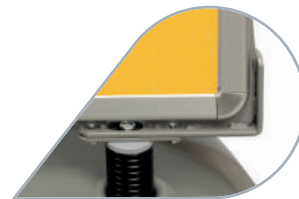

Higher specification corner brackets on 30" x 40" and A0 sizes.



Fully Recyclable

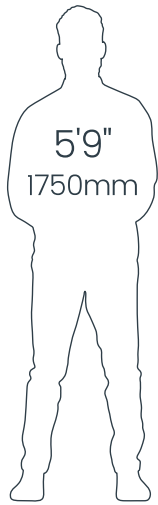

A0



30" x 40"



A1

Instruction Video



Poster Size	Display Area (mm)	O/A Dimensions (w x h x d mm)	Weight (kg) Empty/Full	Colour	Order Code
A1	575 x 822	786 x 1150 x 510	12/48	Silver Frame/Grey Base	SM3AIFRS + SM3SBG
				Black Frame/Black Base	SM3AIFRB + SM3SBB
30" x 40"	744 x 997	956 x 1342 x 609	18.3/81	Silver Frame/Grey Base	SM334FRS + SM3LBG
				Black Frame/Black Base	SM334FRB + SM3LBB
A0	823 x 1173	956 x 1515 x 609	21/83	Silver Frame/Grey Base	SM3A0FRS + SM3LBG
				Black Frame/Black Base	SM3A0FRB + SM3LBB



Be reactive with our clip-on Sightmaster 3 Tactical Header.

- Simply clips on to the top of Sightmaster 3 frames (unclip for poster change).
- Ideal for short term or dual brand promotions - additional advertising space at minimal cost.
- 0.9mm rigid gloss white PVC panel ideal for screen/ digital print or vinyl graphics.
- Supplied complete with clips.
- Custom shapes available, made to order (minimum order quantity 25).

Type	Size (mm)	Order Code
A1	582 x 200	THSM3A1
30" x 40"	751 x 215	THSM334
A0	829 x 230	THSM3A0



Fully Recyclable

Spring Sign

A lower cost alternative to Sightmaster 3 – where optimum outdoor performance isn't required, or when price is king!



- Very competitive pricing.
- A1 poster size only in silver or black finish.
- Matches or betters industry standard spring-based poster signs.
- 25% lighter when filled with water than our premium spring-based Sightmaster 3.
- Front opening aluminium snapframes for quick and easy poster change.
- Anti-glare poster cover sheets protect posters from UV fade.
- White aluminium composite (ACM) back panel suitable for permanent self-adhesive vinyl messaging.
- Built-in wheels for ease of movement – no lifting required.
- Quick and easy no tools assembly.

Poster Size	Display Area (mm)	O/A Dimensions (w x h x d mm)	Weight (kg) Empty/Full	Colour	Order Code
A1	575 x 822	782 x 1120 x 499	11.2/35	Silver Frame/ Grey Base	SSAIFRS + SSAIBG
				Black Frame/ Black Base	SSAIFRBLK + SSAIBBLK



Fully Recyclable



Be reactive with our clip-on Tactical Header.

- Simply clips on to the top of Spring Sign frames.
- Ideal for short term or dual brand promotions – additional advertising space at minimal cost.
- 0.9mm rigid gloss white PVC panel ideal for screen/ digital print or vinyl graphics.
- Supplied complete with clips.
- Custom shapes available, made to order (minimum order quantity 25).

Type	Size (mm)	Order Code
A1	582 x 200	THSM3A1



Fully Recyclable

Cyclone 2

Patent No. 2464696

Eye-catching, stable and stylish.



- Double sided 40" x 60" poster display.
- Front opening 50mm wide white Frameworkz snapframe border, excluding quadrant corner mouldings, can be printed in any design* or is suitable for vinyl text or logos.
- Back panel can be printed to offer brand presence when posters are not in use (no minimum order quantity).
- 700 micron clear PET poster covers, fixed along top edge for security and ease of poster change.
- Black steel cradle with hard wearing pivot axles.
- Water-fillable black HDPE base with built-in wheels for ease of movement.
- Round corners throughout for safety.
- Purpose designed trolley and filling hose available (see page 40 for more details).

*No minimum order quantity.

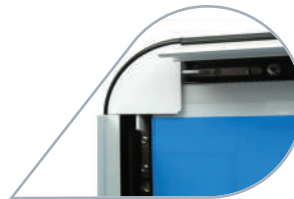

Snapframes for quick and easy poster change.



Hard wearing pivots for friction-free wind movement.

Cyclone 2's unique counter-balanced panel deflects wind safely and creates interest through movement:

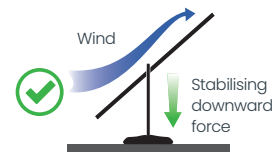

Cyclone 2



Cyclone 2

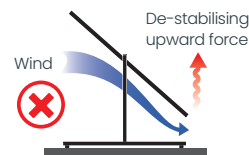

Non-Counterbalanced Sign

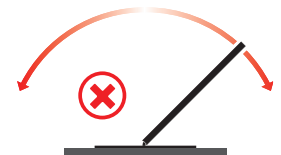

Base Pivoted Sign



Recyclable: aluminium frame, steel cradle, PET poster covers, steel wheel axle, polyethylene base

Poster Size	Display Area (w x h mm)	O/A Dimensions (w x h x d mm)	Weight (kg) Empty/Full	Order Code
40" x 60"	980 x 1502	1206 x 1917 x 702	41/109	CYCLONE2 + SEN34BASE

Sentinel®

The ultimate forecourt poster sign.

EU Design Registration No. 000190954

Sentinel® A1 Patent No. 2464773

Instruction Video



- Sentinel® Tactical Header available separately (see page 24).
- Smooth rounded corners for safety.
- Stainless steel tamper-proof fixings retain poster cover at the top (not A1 size).
- Durable powder coated steel frame (50 x 25mm oval).
- Easy poster change by one person.
- Silver border and frame as standard.
- Back panel can be printed to offer brand presence when posters are not in use (no minimum order quantity).
- Magnetic sealed polycarbonate poster covers offer strength and superior poster protection.
- Black water-fillable base manufactured from recycled polyethylene. Custom colours available (minimum order quantity 25).
- Built-in wheels - easy to move with our purpose designed trolley (see page 40 for details).

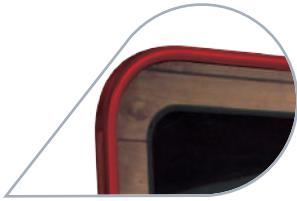

Custom frame colours (minimum order quantity 25) and/or printed border available (no minimum order quantity).



Magnetic poster covers for quick and easy poster change. Bottom opening for larger sizes, side opening for A1.



Sentinel® working hard for major retailers across the country.



Purpose-designed trolley available separately (see page 40 for details).

Being able to display bold attention grabbing marketing messages outside a store or premises is key to driving footfall. Nothing does that better than Sentinel® - now in a choice of 4 high impact poster sizes.

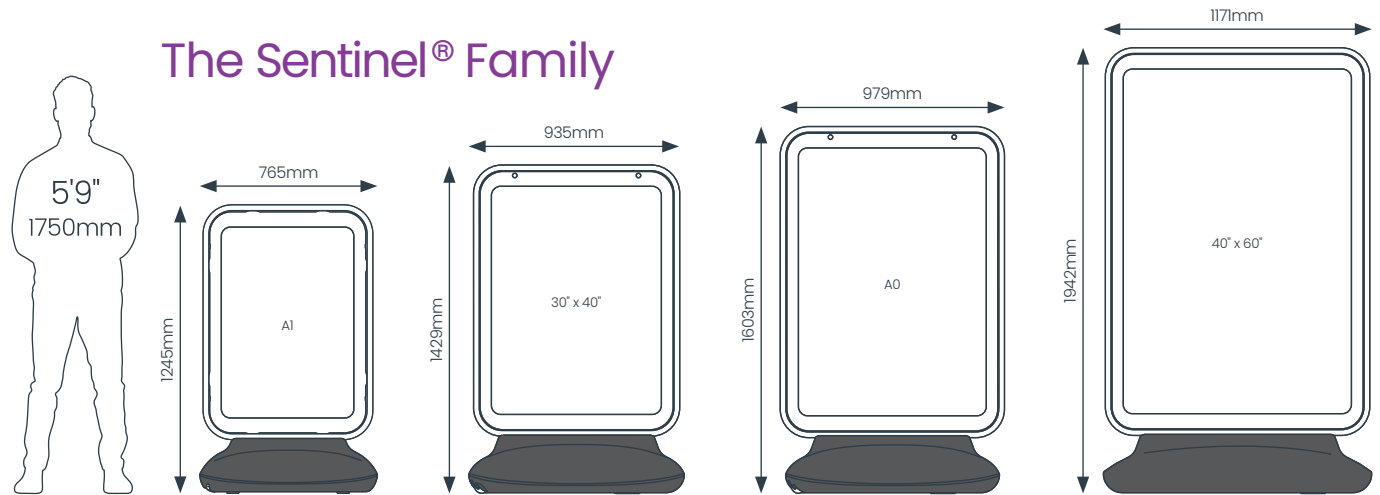

Poster Size	Display Area (mm)	O/A Dimensions (w x h x d mm)	Weight (kg) Empty/Full	Stock Colour Frame/Base	Order Code
A1	580 x 830	765 x 1245 x 650	18.5/65	Silver/Black	SENA1STD + SENA1BASE
30" x 40"	748 x 1004	935 x 1429 x 704	27/99		SEN34MK4GG + SEN34BASE
A0	827 x 1178	979 x 1603 x 704	31/103		SENA0MK4GG2 + SEN34BASE
40" x 60"	1002 x 1512	1171 x 1942 x 894	37.5/150		SEN46MK4GG + SEN46BASE



Recyclable: steel frame, polycarbonate poster covers, part recycled polyethylene base

Sentinel® Tactical Header

Be reactive with our clip-on Sentinel® header.



- Simply clips on to the top or side of Sentinel® frames.
- Ideal for short term or dual brand promotions - additional advertising space at minimal cost.
- 0.9mm rigid gloss white PVC panel ideal for screen/ digital print or vinyl graphics.
- Supplied complete with clips.
- Custom shapes available (made to order - minimum order quantity 25).



Fully Recyclable

Type	Size (mm)	Order Code
A1	625 x 200	THSENA1
30" x 40"	795 x 215	THSEN34
A0	870 x 230	THSENA0
40" x 60"	1050 x 245	THSEN46



Simply clips on top of Sentinel® and Sentinel® Banner frames (clips available separately).



Defender

Permanent large format poster display.



- Front opening 38mm profile aluminium snapframes for quick and easy poster change.
- Anti-glare PET poster covers give excellent clarity.
- Heavy concrete base for optimum stability.
- Steel sub frame with panel area below poster frame suitable for permanent branding (no minimum order quantity).
- Back panel can be printed to offer brand presence when posters are not in use (no minimum order quantity).
- Silver anodised snapframe with white steelwork as standard. Custom colours also available made to order (minimum order quantity 25).
- Please call our sales team for delivery charge costs.

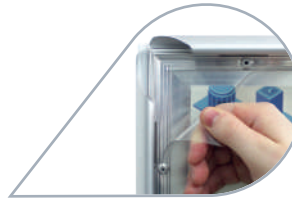

Snapframes for quick and easy poster change.



Steel sub-frame panel suitable for permanent branding.



Recyclable: aluminium snapframes, steel sub-frame, PET poster covers

Poster Size	Display Area (w x h mm)	O/A Dimensions (w x h mm)	Base Diameter (mm)	Weight (kg)		Order Code
				Base	Frame	
30" x 40"	729 x 983	818 x 1447	600	53	15	DEF34WA + KIT01
40" x 60"	984 x 1492	1072 x 1855	800	80	24	DEF46WA + KIT02

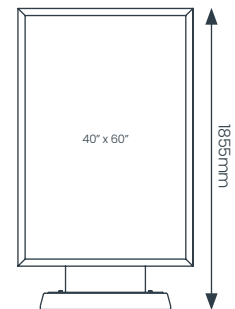
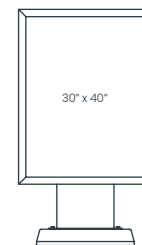

Ecoflex (range overview)

Economical and eco-friendly – ideal for pavement, roadside and forecourt promotions.



Unique patented design. Incredibly secure – wedge simply slots through panel & locks into place.

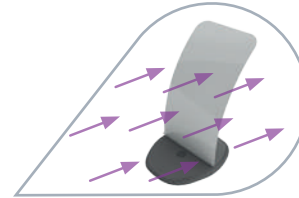

Ecoflex pavement signs tested to Storm Force 10 Beaufort Scale (not chalkboard variant).

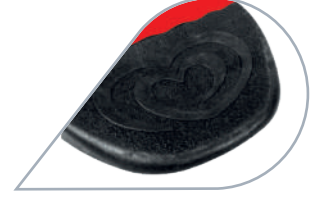

Bases available with embossed logos (minimum order quantity 500).

- Fully recyclable.
- Lightweight, portable design.
- Gloss white 1.2mm aircraft grade aluminium panel – ideal for screen/digital print or vinyl graphics.
- Rounded corners for pedestrian safety.
- Maximum visual impact with optimised display area, plus panel shape opportunities.
- Option of black High Pressure Laminate chalkboard panels.
- Rugged recycled PVC base provides low centre of gravity and high stability.



The Ecoflex Family

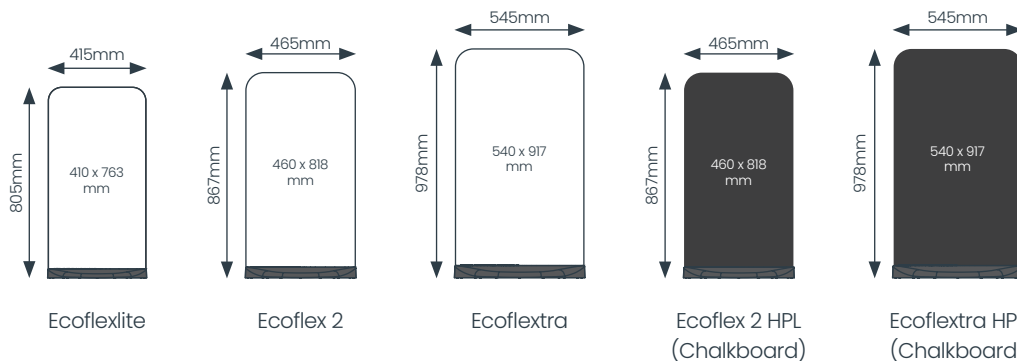

Ecoflexlite

Light on price, big on performance.

Instruction Video



- Ecoflexlite may be the smallest in our range, but it packs a punch with its 410mm x 763mm display area.
- Aircraft grade 1.2mm aluminium panel is ideal for screen/digital print or vinyl graphics.
- Unique patented wedge means assembly and disassembly in seconds with no tools required.
- Recycled PVC base provides great stability.
- Wind tested for maintenance free use whatever the weather.
- Option to have embossed logo in base (minimum order quantity 500).



Wedge simply slots through panel and locks into place.

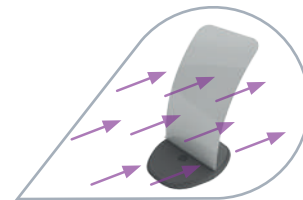

Tested to Storm Force 10 Beaufort Scale.



Fully Recyclable

Panel Size (mm)	Display Area (mm)	O/A Dimensions (w x h x d mm)	Weight (kg)	Order Code
410 x 795	410 x 763	415 x 805 x 500	7	ECOFLEXLITE

Ecoflex 2

The Nation's No.1

Instruction Video



- The top selling individual pavement sign in the UK.
- Mid sized 460mm x 818mm display area.
- Aircraft grade 1.2mm aluminium panel is ideal for screen/digital print or vinyl graphics.
- Unique patented wedge means assembly and disassembly in seconds with no tools required.
- Recycled PVC base provides great stability.
- Wind tested for maintenance free use whatever the weather.
- High Pressure Laminate chalkboard option also available.
- Option to have embossed logo in base (minimum order quantity 500).
- Opportunities for shaped and oversized panels for maximum impact.



Wedge simply slots through panel and locks into place.

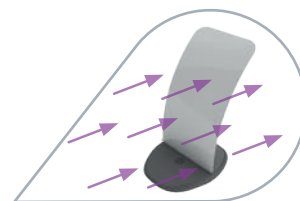

Tested to Storm Force 10 Beaufort Scale.

Panel Options	Panel Size (mm)	Display Area (mm)	O/A Dimensions (w x h x d mm)	Weight (kg)	Order Code
Aluminium	460 x 850	460 x 818	465 x 867 x 540	7.8	ECOFLEX-2
Chalkboard	460 x 850	460 x 818	465 x 867 x 540	8.1	ECOFLEX-2-HPL



Fully Recyclable

Ecoflextra

Bigger sign, bigger impact.

Instruction Video



- Designed for long range visibility to grab attention.
- Large 540mm x 917mm display area.
- Aircraft grade 1.2mm aluminium panel ideal for screen/digital print or vinyl graphics.
- Unique patented wedge means assembly and disassembly in seconds with no tools required.
- Recycled PVC base provides great stability.
- Wind tested for maintenance free use whatever the weather.
- High Pressure Laminate chalkboard option also available.
- Option to have embossed logo in base (minimum order quantity 500).
- Opportunities for shaped and oversized panels for maximum impact.



Wedge simply slots through panel and locks into place.

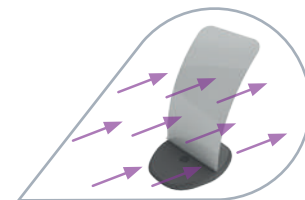

Tested to Storm Force 10 Beaufort Scale.



Fully Recyclable

Panel Options	Panel Size (mm)	Display Area (mm)	O/A Dimensions (w x h x d mm)	Weight (kg)	Order Code
Aluminium	540 x 952	540 x 917	545 x 978 x 540	11.3	ECOFLEXTRA
Chalkboard	540 x 952	540 x 917	545 x 978 x 540	11.7	ECOFLEXTRA-HPL

Ecoflex Custom Shaped Panels

Create truly unique and eye catching designs with custom shaped aluminium panels, brought to life with our vibrant screen and digital print.

Product	Max. Display Area dimensions(w x h mm)
Ecoflexlite	410 x 763
Ecoflex 2	623 x 918
Ecoflextra	696 x 1017



Minimum order quantity 25.



Ecoflex Chalkboard Panels

- 3mm High Pressure Laminate panel material is a tough writing surface ideal for traditional chalk and liquid chalk pens.
- Great for personalised messages, changing promotions and special offers.
- Options of branded panels using direct print or self adhesive vinyl.
- Liquid Chalk Pens available (see page 93).
- Chalkboard panels are available as standard on Ecoflex 2 and Ecoflextra models.

Note : Chalkboard panels can only be used in bases manufactured to suit a 3mm thick panel.

Ecoflex 2 Totem & Ecoflexextra Totem

Extra tall panels for maximum impact.



- 3mm thick Aluminium Composite (ACM) panels.
- Variable height up to maximum shown below.
- Ideal for screen/digital print or vinyl graphics.
- Unique patented wedge means assembly and disassembly in seconds with no tools required.
- Recycled PVC base offers good stability.
- Suitable for indoor or sheltered outdoor use.
- Totem panels can **only** be used in Ecoflex 2 or Ecoflexextra bases which are manufactured to suit a 3mm thick panel.



Wedge simply slots through panel and locks into place.



Ecoflex 2 Totem



Ecoflexextra Totem

Type	Panel Size (mm)	Display Area (mm)	O/A Dimensions (w x h x d mm)	Weight (kg)	Availability	Order Code
Ecoflex 2 Totem	460 x 1473	460 x 1441	465 x 1490 x 540	9.5	In Stock	ECOFLEX-2-TOTEM
Ecoflexextra Totem	540 x 1463	540 x 1428	545 x 1490 x 540	13	Made to order	ECOFLEXTRATOTEM



Fully Recyclable

A-Board

A completely smooth panel for undisrupted vinyl/print application.



- Double sided 500 x 700mm display area.
- Fixing free aluminium panel surface ideal for screen/digital print or vinyl graphics.
- Folds flat for easy storage and portability.
- Steel tube frame (32mm diameter), powder coated white as standard.
- Supplied pre-assembled and ready for use.
- Frame can be customised to any colour (minimum order quantity 200).



Rounded corners for style and safety.

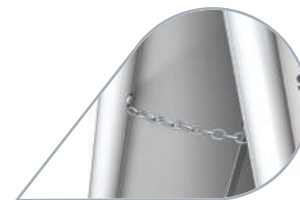

Chrome oval chain maintains optimum leg angle.



Fully Recyclable

Display Area (mm)	O/A Dimensions (w x h x d mm)	Weight (kg)	Colour	Order Code
500 x 700	564 x 860 x 700	9	White	AB100W2FP

Budget A-Board

Our most economical A-Board.



- 3mm gloss white high impact polystyrene (HIPS).
- Double sided 480 x 812mm display area for self-adhesive vinyl graphics.
- Comes flat packed, pre-assembled with fixed hinges – simply adjust to the footprint that you require (maximum 680mm for optimum stability).
- Lightweight, folds flat for easy storage and portability.
- Rounded top corners for increased safety and style.
- Suitable for sheltered locations only.
- Chalkboard version available, suitable for use with Liquid Chalk Pens only (see page 93).

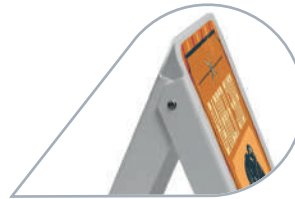

Fixed hinge for adjustable open width.



Rounded corners for added style and safety.



Fully Recyclable

Display Area (mm)	O/A Dimensions (w x h x d mm)	Weight (kg)	Option	Order Code
480 x 812*	505 x 830 x 680	4.3	White	ABPSP
			Chalkboard	ABPSCB

*Recommended to allow 10mm border all round.



Chalkboard option.

Waterbase A-Board

Our smallest A-Board offering.



- Durable polyethylene construction.
- Water fill (6.5 litres) or sand fill for optimum stability.
- Lightweight when empty and folds flat for easy transportation and storage.
- Graphic area 320 x 559mm (sticker inlay required).
- Open to any required width up to 570mm.
- We recommend using high tack vinyl for graphics.
- Vinyl application available (no minimum order quantity).
- Also available in custom colours (minimum quantity 500).



Waterfill panels for stability



Built-in carry handle

Display Area (mm)	O/A Dimensions (w x h x d mm)	Weight (kg)			Order Code
		Empty	Water-filled	Sand-filled	
320 x 559*	410 x 754 x 570	2.6	9.2	11.7	WBABGREY

*Recommended to allow 3mm border all round (recess is 326 x 565mm).



Fully Recyclable

Waterbase Pyramid

Eye catching display pillar with sticker inlay graphic.



- Durable polyethylene construction.
- Water fill (5.5 litres) or sand fill for optimum stability.
- Simple push fit assembly.
- Graphic area 330 x 385mm with 12.5mm corner radius (sticker inlay required).
- Stands taller than most other pavement signs for eye catching display.
- Supplied flat packed in 3 parts for ease of distribution.
- We recommend using high tack vinyl for graphics.
- Vinyl application available (no minimum order quantity).
- Also available in custom colours (minimum quantity 500).

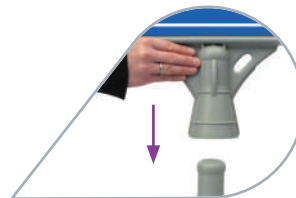

Parts simply push together.

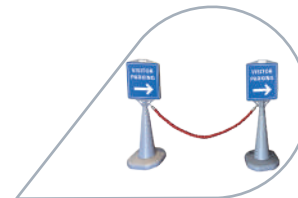

Waterbase pyramid barrier system.



Fully Recyclable

Display Area (mm)	O/A Dimensions (w x h x d mm)	Weight (kg)			Order Code
		Empty	Water-filled	Sand-filled	
330 x 385	370 x 1125 x 370	2.3	7	11.4	WBPSGREY

Sentinel® Banner

Forecourt sign with printed banner display.



- Steel frame with silver powder coated finish as standard – also available in custom colours (minimum order quantity 25).
- Black water-fillable polyethylene base, precisely calculated for optimum stability, made using recycled materials.
- Built in wheels and purpose designed trolley make it easy to move into position (see page 40 for details).
- Supplied complete with set of elasticated banner ties.
- Digitally printed double-sided banners available to order (750gsm reinforced light block PVC as standard).



Elasticated banner ties supplied.



Built-in wheels for ease of movement.



Recyclable: steel frame, part recycled polyethylene base, optional PVC banner

Banner Size	Display Area (mm)	O/A Dimensions (w x h x d mm)	Weight (kg) Empty/Full	Stock Colour Frame/Base	Order Code
30" x 40"	742 x 996	935 x 1429 x 704	25/97	Silver/Black	SENBAN34GG + SEN34BASE
40" x 60"	996 x 1504	1171 x 1942 x 894	38/146		SENBAN46GG + SEN46BASE

Sign Covers

Sleeves over a forecourt poster sign for high-visibility promotion and medium-term campaigns.



- Promotes new service offers, new products and new site ownership/rebranding.
- For medium-term promotions typically 3 to 12 months.
- Borderless printed designs provide up to 38% more display area than the posters they cover.
- Suitable for the following signs in all sizes - Sentinel®, Defender, Sightmaster 3 and Spring Sign.
- Tear-proof polyester reinforced PVC material and stitched seams for excellent outdoor performance.
- Tethering holes in lower edge to suit cable-tie or similar for optional added security.
- For forecourt, supermarket, retail, service, exhibition and leisure-site locations.
- Custom sizes available.
- No minimum order quantity.



Easy-fit cover.



Tether holes in lower edge.

Sign Type	To fit over poster panel size	Cover Dimensions (mm)	Order Code
Fixed-Mount Frame	A1	792 x 1010	SCFIXA1
	30" x 40"	960 x 1210	SCFIX34
	A0	1039 x 1373	SCFIXA0
	40" x 60"	1214 x 1707	SCFIX46
Spring-Mounted Frame	A1	730 x 925	SCSPRNGA1
	30" x 40"	920 x 1092	SCSPRNG34
	A0	1015 x 1278	SCSPRNGA0
	40" x 60"	1170 x 1600	SCSPRNG46



Fully Recyclable

POW! Sign

Patent No's: GB2541956

EP3168826

Going above and beyond the standard rectangular poster or banner sleeve.



- Panel sleeve design enables easy and cost effective graphic updates.
- Maintenance free reinforced polypropylene sleeve (15mm thick).
- Vibrant, larger than life images for high impact promotion.
- Long range visibility to capture both pedestrians and motorists attention.
- Wholly customisable with endless text and image combinations.
- Freestanding - no groundwork needed. Water-fillable and concrete base options available.
- Made to order (see minimum order quantities opposite).



Ideal for breakout shapes and disruptive designs.

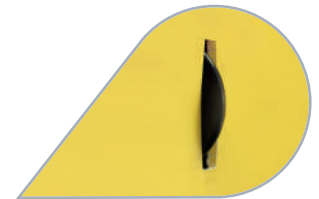

Panel slots into place effortlessly.



Cost effective graphics, updatable in 1 minute.



Purpose designed trolley & hose available separately (see page 40).



Recyclable: steel frame, steel fasteners, polyethylene base & steel axle, bolt to ground steel frame

An innovation in large format double-sided signs, *POW!* delivers striking breakout shapes that are guaranteed to draw attention.

Instruction Video



Base options



Waterfill Base

- Black water-fillable polyethylene.
- Built-in wheels for positioning (optional trolley available).



Concrete Base

- For more permanent positioning.
- Lower cost material but generally higher distribution cost.



Bolt to Ground

- A permanent installation option.

The *POW!* Family



Small *POW!*

Max Display Area:
980mm x 1180mm
(minimum order quantity 10*)



Medium *POW!*

Max Display Area:
1180mm x 1353mm
(no minimum order quantity
with waterfill base)



Large *POW!*

Max Display Area:
1425mm x 1667mm
(minimum order quantity 10*)

*Replacement panels no minimum order quantity.

Trolley and Hose

Convenient assistance for a selection of our large format signs.

- Purpose designed flat pack trolley for easy and safe movement of Sentinel[®], Sentinel[®] Banner, Cyclone 2, large-based Sightmaster 3 and *POW!*
- 3m hose with tap connector also available for convenient base filling.



Item	O/A Dimensions (mm)	Weight (kg)	Order Code
Trolley	225 x 1220 x 225	2.5	TROLLEY
Hose	3000 x 13	1	SENHOSE
Adaptor*	90 x 45 x 48	0.125	TROLLEYADAPTOR

* Only used with old Sightmaster 2 units.



Recyclable: steel trolley handle

Chalk Insert Panels

Turn any poster display into a chalkboard display, with these simple and inexpensive insert panels.



A-Master with Chalk Insert Panel.

- High strength 500 micron black polypropylene (textured surface to front, smooth matt reverse).
- Suitable for use with Liquid Chalk Pens.
- Suitable for screen/digitally printed graphics (no minimum order quantity) or vinyl application.
- Resistant to dirt and chemicals – stays looking new for longer.
- High temperature tolerance – long life even in outdoor use.
- Available in 3 stock sizes: A2, 20" x 30" and A1.
- Other sizes available made to order (up to 650 x 1100mm, no minimum order quantity).

Poster Size	O/A Dimensions (mm)	Order Code
A2	420 x 594	INFA2CCB
20" x 30"	508 x 762	INF2030CCB
A1	594 x 841	INFA1CCB



Fully Recyclable

A selection of products perfectly suited to Chalk Insert Panels:



Swinger Poster Pocket



Slimlok Poster Case



i-Stand



Booster



Headlinerlite



Sightmaster 3



Snapframes

Premier A-Board

Unique design that leads the market on performance and functionality.

Instruction Video



Available in 2 sizes and 2 stock finishes with a choice of panel materials.

- 38mm x 38mm powder coated steel frame.
- Satin black and satin wood grain stock finishes.
- Unique hard-wearing rubber hinges allow feet to self-level on uneven surfaces and offer finger protection when handling.
- Reversible panels for added message flexibility and convenience.
- Fully assembled and ready for use straight out of the box.
- Frames also available in any RAL colour (minimum order quantity 25).

Panel material options

- 3mm black high pressure chalkboard laminate – for traditional chalk or liquid chalk pens.
- 3mm gloss white aluminium composite (ACM) – strong, light and very rigid.
- 5mm satin/matt white foam PVC – strong and lightweight.

Printed/shaped panel options.

- Custom shaped top edge available for all panel materials (minimum order quantity 25).
- Direct to surface digital/screen print available (no minimum order quantity).

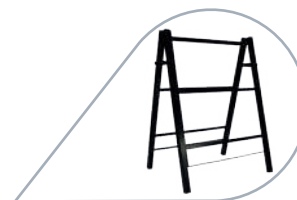

Frame only also available.



Recyclable: steel frame, steel stays, ACM panels, foam PVC panels



Stylish locking arms.



Hard wearing rubber hinges.



Slide-in reversible panels in either...



High pressure chalkboard laminate.



White aluminium composite (ACM) or Foam PVC.

OR

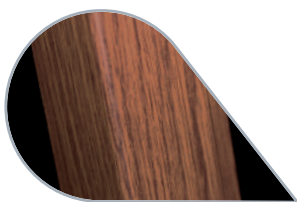

Wood Effect Finish

- Beautiful wood-grain patterned powder-coating in a satin sheen finish.
- Out performs real wood and maintains a high quality new wood appearance for longer.
- Other patterns/colours available (minimum order quantity and extended lead times apply).

Frame Colour	Size (mm)	Panel Material	Display Area (mm)	O/A Dimensions (w x h x d mm)	Weight (kg)	Order Code
Black Steel Frame	Small	3mm Black High Pressure Chalkboard Laminate	540 x 813	674 x 920 x 600	12	PREMASMMHPL
		3mm Gloss White Aluminium Composite (ACM)			11	PREMASMMACM
		5mm White Foam PVC			10.5	PREMASMMFOAM
Black Steel Frame	Large	3mm Black High Pressure Chalkboard Laminate	710 x 1049	843 x 1184 x 705	19	PREMALGMHPL
		3mm Gloss White Aluminium Composite (ACM)			16.5	PREMALGMACM
		5mm White Foam PVC			15.5	PREMALGMFOAM
Wood Effect Steel Frame	Small	3mm Black High Pressure Chalkboard Laminate	540 x 813	674 x 920 x 600	12	WEMPRDOSMHPL
		3mm Gloss White Aluminium Composite (ACM)			11	WEMPRDOSMACM
		5mm White Foam PVC			10.5	WEMPRDOSMFM
Wood Effect Steel Frame	Large	3mm Black High Pressure Chalkboard Laminate	710 x 1049	843 x 1184 x 705	19	WEMPRDOLGHPL
		3mm Gloss White Aluminium Composite (ACM)			16.5	WEMPRDOLGACM
		5mm White Foam PVC			15.5	WEMPRDOLGFM
Satin Black Frame Only	Small	-	-	674 x 920 x 600	8	METALFRAMEASSYSMCH
	Large	-	-	843 x 1184 x 705	11.5	METALFRAMEASSYLGRCH
Wood Effect Frame Only	Small	-	-	674 x 920 x 600	8	WEMFRAMEDOSM2
	Large	-	-	843 x 1184 x 705	11.5	WEMFRAMEDOLRG2

Chalk A-Boards by Woodworkz®

Woodworkz® is our joinery-quality brand of in-house manufactured real wood sign and display products.

Large Premium Full Frame



Medium Premium Reversible

Small Standard Full Frame

We only use sustainable and certified timber sourced from approved sawmills and distributors.

All models feature:

- 2-coat, low VOC, stained and satin lacquered for excellent weather protection.
- Stock 'Country Oak' finish.
- Good grain definition to emphasise real wood appeal.
- Single side locking-stay for stability on small and medium frames, 2 side locking-stays on large frames.
- Non-slip rubber feet.
- Precision mitres and joints – joinery quality.
- Hard-wearing laminate chalk panels for traditional chalk or liquid chalk pens.
- Bespoke sizes and colours available subject to minimum order quantity.

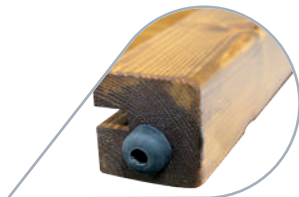

Rubber feet.

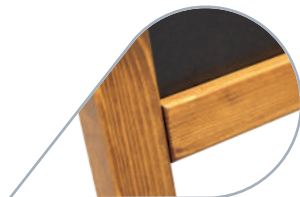

Durable finish.



Precision joinery.

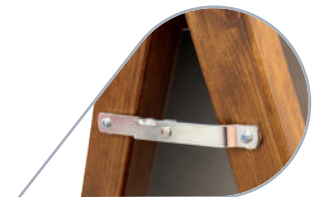

Locking stay.

Our Woodworkz® Chalk A-Board range offers 7 models across 3 styles.

- Direct to surface print available (no minimum order quantity).
- Custom frame colours and sizes available to order (minimum order quantity 10).



Standard Full Frame

- 3 sizes – small, medium and large.
- 45 x 21mm frame profile.
- 6mm exterior chalk-face laminated MDF panels.
- Fully recyclable.



Premium Full Frame

- 2 sizes – medium and large.
- 45 x 45mm frame profile.
- 6mm exterior chalk-face laminated MDF panels.
- Fully recyclable.



Premium Reversible

- 2 sizes – medium and large.
- 45 x 45mm frame profile.
- 3mm high pressure laminate (HPL) reversible slide-in curve-topped panels.
- Recyclable: frame, steel locking stays and hinges.

Style	Size	Display Area (mm)	O/A Dimensions (w x h x d mm)	Weight (kg)	Order Code
Standard Full Frame	Small	367 x 572	470 x 776 x 500	5	WCABCOSS
	Medium	572 x 772	671 x 967 x 613	8.5	WCABCOMS
	Large	702 x 1072	801 x 1255 x 784	13	WCABCOLS
Premium Full Frame	Medium	572 x 772	671 x 972 x 659	11.5	WCABCOMP
	Large	702 x 1072	801 x 1260 x 830	17	WCABCOLP
Premium Reversible	Medium	537 x 798	637 x 950 x 604	9.5	WCABCOMPRV
	Large	704 x 1034	804 x 1176 x 736	13	WCABCOLPRV



Recyclable

Banner Frame

Lightweight aluminium banner frame for ground siting.

Wall mounted variant available – see page 87



Simple push-fit assembly.

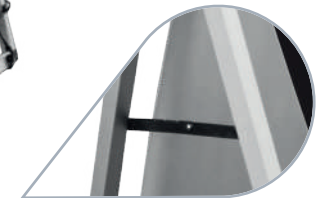

Hinged stays.

- A-frame design for single or double-sided banners.
- Ground pegs included for soft ground anchoring.
- Flat-pack, no tools assembly. Complete with padded carry bag.
- Anodised frame finish resists scratches to maintain best appearance.
- Self-adjusting bungee hooks hold eyeleted banners under tension.
- Bungees included.
- Recommended banner size: 2840 x 1090mm.
- Use with caution outdoors – light winds only.
- Printed Banners available.



Recyclable: aluminium tubes, steel stays, steel pegs, steel hinges

Display Area (mm)	O/A Dimensions (w x h x d mm)	Weight (kg)	Order Code
2840 x 1090	3000 x 1250 x 800	6.5	BANFRAME

Bollard Wraps

Transform any bollard into a high impact advertisement.

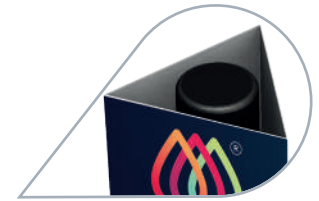

Bollard Wrap detail view.



- Simply pops over existing bollards for effective seasonal marketing or promotion of new products and services.
- Suitable for a wide range of bollard sizes from 100mm - 200mm diameter.
- Choose from 3 heights: 800mm, 1000mm and 1200mm.
- 3 sided and 4 sided options available.
- Graduated tabs allow quick and easy assembly without the need for any tape, fixings or tools.
- Fine-fluted 3mm Correx polypropylene for resilient outdoor use.
- No minimum order quantity.



Fully Recyclable

Outdoor (Indoor)
Free-Standing/Floor Mounted

Flying Banners

The popularity of Flying Banners, sometimes referred to as Event Flags, Sail Flags, Beach Flags or Feather Flags, has grown tremendously in recent years.

Proud to be at the forefront of this revolution our high quality printed textile flags are supported on high-strength carbon composite poles and friction-free bearing spindle, on a choice of base, ground spike or bracket mount.

We have invested heavily in research, product development and testing to ensure materials, print and product performance are amongst the best available whilst offering very competitive pricing.

Outdoor Performance

Naturally, Flying Banner life span depends on how and where they are used.

Teardrop flags generally last longer than Feather flags as the banner fabric is held in tension and experiences less movement.

Whichever style you choose we recommend taking them in overnight and avoid use in strong winds (i.e. 24+ mph wind speeds/Beaufort scale 6). Failure to do so will significantly shorten the lifespan of the product.

* Flag templates available on request, if own flag production preferred.



A choice of 3 shapes and 3 sizes.

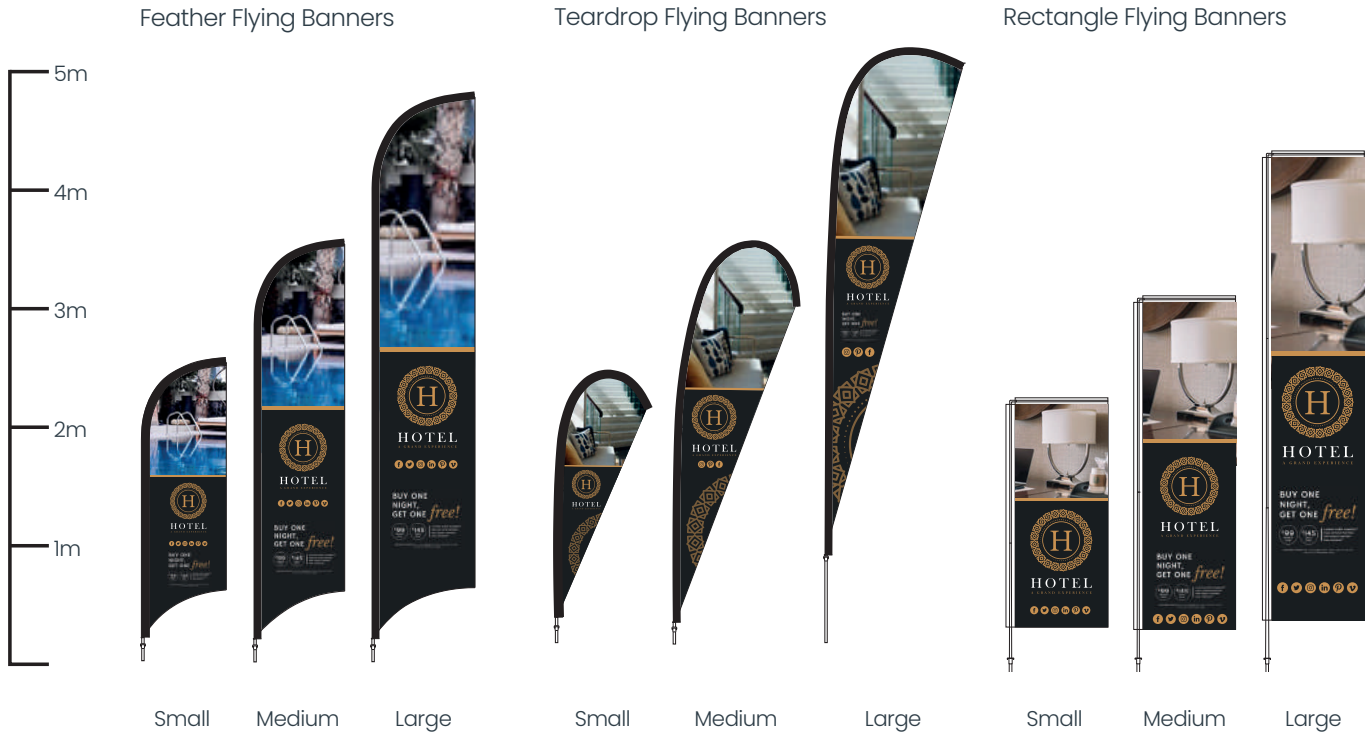

Leading Quality and Performance

Friction-Free Bearing Spindle

Our intelligently designed and engineered steel bearing spindle features in all our outdoor base and mounting bracket solutions (see page 54).

Friction-free rotation allows the flag to easily align to the wind, minimising stress and optimising flag visibility, performance and life-span.

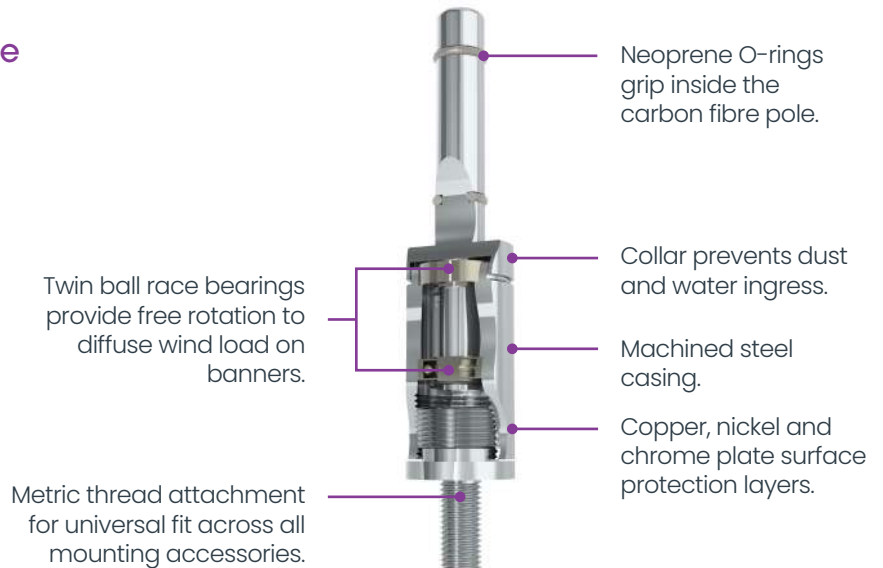

Carbon Composite Banner Poles

Our light-weight, high-strength, sectional poles come with a 3 year manufacturer's warranty. They are stronger and more stress/gust resistant than any aluminium pole offering.

Reuse for years with replacement flags as required.

Flag Materials

There is a choice of standard 110gsm close-weave or 115gsm air-mesh polyester textiles, both offering an excellent combination of strength and image vibrancy.

Small holes in air-mesh allows some air to pass through the fabric thus reducing wind fatigue on the flag. This makes it a good choice for windy situations, particularly in combination with the elasticated pole sleeve.

Recycled 'rPET' textile available at additional cost. Minimum order quantities may apply subject to confirmation at time of enquiry.

Sublimation Printing

All flying banner flags are printed by a dye-sublimation process which uses special inks and a post-print heating process to 'fix' the ink into the fabric, making it resilient and washable as well as maximising the mirror image show-through on the reverse.

Flag Pole Sleeves

The majority of our flags are produced with printed, non-elasticated wrap-around pole sleeves, providing maximum possible print area. When extra durability is required there is the option of a reinforced black or white elasticated sleeve. This would be recommended for exposed or unattended locations, such as roadside and 24/7 retail sites where the flag may not be taken in overnight.

Finishing

To complete the attention to detail all Flying Banners come with draw-string tethers to adjust tensioning, double-stitched hems and reinforced pole sleeve ends for optimum flag life, and a black canvas carry bag to store pole, flag and ground spike when not in use.



High strength.

Sectional poles.

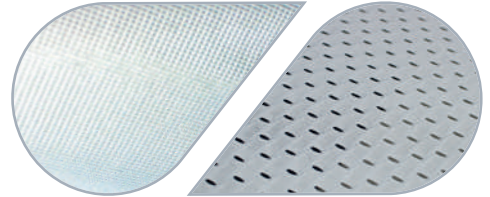

Standard.

Air-mesh.



Front.

Reverse.



Wrap-around.

Elasticated.



Draw string
tether.

Double stitched
hems.

Feather Flying Banner

Feather shaped banner which flutters and rotates in the wind.

Instruction Video



Showing white reinforced elasticated pole sleeve and Base Plate.

- High strength sectional carbon fibre pole.
- Market leading detail, quality and performance.
- Printed flags in standard or airmesh polyester textile to order.
- Choice of mounting accessories available.
- Printed non-elasticated wrap-around pole sleeves give maximum possible printed display area.
- We recommend an elasticated pole sleeve for increased durability.

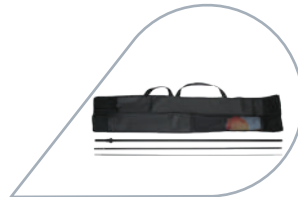

Black canvas bag supplied with each pole includes compartments to store flag, ground spike and water bag.

Feather Pole & Bag	O/A Height (mm)	Pole & Bag Weight (kg)	Order Code
Small	2493	1	FBFSM
Medium	3480	1.5	FBFMD
Large	4688	2	FBFLG

Feather Flag	Flag Size Wrap around (mm)	Order Code Printed flags with Wrap around printed pole sleeve	Flag Size Elasticated (mm)	Order Code Printed flags with reinforced elasticated black pole sleeve	Order Code Printed flags with reinforced elasticated white pole sleeve
Small	698 x 2323	FBFSMBAN(SW)	701 x 2246	FBFSMBANBEH(SW)	FBFSMBANWEH(SW)
Medium	750 x 3251	FBFMDBAN(SW)	753 x 3191	FBFMDBANBEH(SW)	FBFMDBANWEH(SW)
Large	850 x 4421	FBFLGBAN(SW)	853 x 4351	FBFLGBANBEH(SW)	FBFLGBANWEH(SW)

For a printed air-mesh flag add 'A' to the end of the appropriate order code above.



Teardrop Flying Banner

Teardrop shaped banner which rotates in the wind.

Instruction Video



Showing wrap-around pole sleeve and Tank Base.

- High strength sectional carbon fibre pole.
- No fluttering means less distress and increased durability.
- Market leading detail, quality and performance.
- Printed flags in standard or airmesh polyester textile to order.
- Choice of mounting accessories available.
- Printed non-elasticated wrap-around pole sleeves give maximum possible printed display area.
- We recommend an elasticated pole sleeve for increased durability.



Black canvas bag supplied with each pole includes compartments to store flag, ground spike and water bag.

Teardrop Pole & Bag	O/A Height (mm)	Pole & Bag Weight (kg)	Order Code
Small	2250	1	FBTSM
Medium	3340	1.5	FBTMD
Large	4925	2	FBTLG

Teardrop Flag	Flag Size Wrap around (mm)	Order Code Printed flags with Wrap around printed pole sleeve	Flag Size Elasticated (mm)	Order Code Printed flags with reinforced elasticated black pole sleeve	Order Code Printed flags with reinforced elasticated white pole sleeve
Small	771 x 2060	FBTSMBAN(SW)	800 x 1992	FBTSMBANBEH(SW)	FBTSMBANWEH(SW)
Medium	1048 x 3130	FBTMDBAN(SW)	1067 x 3062	FBTMDBANBEH(SW)	FBTMDBANWEH(SW)
Large	1144 x 4122	FBTLGBAN(SW)	1177 x 4052	FBTLGBANBEH(SW)	FBTLGBANWEH(SW)

For a printed air-mesh flag add 'A' to the end of the appropriate order code above.



Rectangle Flying Banner

Instruction Video



Rectangle shaped banner which flutters and rotates in the wind.

- High strength sectional carbon fibre pole.
- Horizontal top pole ensures branding is always on show, with or without wind.
- Market leading detail, quality and performance.
- Printed flags in standard or airmesh polyester textile to order.
- Choice of mounting accessories available.
- Printed non-elasticated wrap-around pole sleeves give maximum possible printed display area.
- We recommend an elasticated pole sleeve for increased durability.

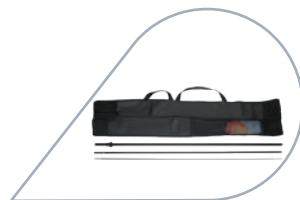

Black canvas bag supplied with each pole includes compartments to store flag, ground spike and water bag.

Showing black reinforced elasticated pole sleeve and Cross Base and Water Bag.

Rectangle Pole & Bag	O/A Height (mm)	Pole & Bag Weight (kg)	Order Code
Small	2115	1	FBRSM
Medium	2897	1.5	FBRMD
Large	4020	2	FBRLG

Rectangle Flag	Flag Size Wrap around (mm)	Order Code Printed flags with Wrap around printed pole sleeve	Flag Size Elasticated (mm)	Order Code Printed flags with reinforced elasticated black pole sleeve	Order Code Printed flags with reinforced elasticated white pole sleeve
Small	780 x 1770	FBRMBAN(SW)	782 x 1752	FBRMBANBEH(SW)	FBRMBANWEH(SW)
Medium	780 x 2530	FBRMDBAN(SW)	782 x 2552	FBRMDBANBEH(SW)	FBRMDBANWEH(SW)
Large	780 x 3580	FBRLGBAN(SW)	782 x 3602	FBRLGBANBEH(SW)	FBRLGBANWEH(SW)

For a printed air-mesh flag add 'A' to the end of the appropriate order code above.



Mounting Accessories For Flying Banners

Tank Base



- Purpose designed water or sand fillable black HDPE base with our leading low friction bearing spindle for all flag sizes.
- Far superior to alternative parasol base offerings.
- 14 litre capacity, for water or kiln-dried sand.
- Designed for ease of handling even when full - satisfies manual handling guidelines.
- Stackable design - second tank (part FBSMTK) recommended for large flags outdoors. Provides up to 40kgs of ballast but remains easy and safe to carry in 2 parts.
- Screw cap for ease of filling.

Item	O/A Dimensions (w x h x d mm)	Weight (kg)			Order Code
		Empty	Water-filled	Sand-filled	
Tank Base + Spindle	455 x 245 x 255	2.0	15	23.0	FBSMTK+TKBRG
Tank Base only	455 x 110 x 455	1.2	14.2	22.2	FBSMTK
Spindle only	100 x 132 x 100	0.8	-	-	TKBRG



Wheel Base



- Black powder coated steel feet with low friction bearing spindle (total weight 4kg).
- Folding design for easy storage.
- V shape allows base to be wedged under any parked vehicle wheel (or driven onto).
- Suitable for all tyre sizes.

Item	Flag and Pole Compatibility	Typical Ground Clearance (m)	Order Code
Wheel Base	See below	-	FBWHEEL(2)
Conversion kit 1	Small Feather flag + medium pole	1.3	FBCONKIT1
Conversion kit 2	Small Teardrop flag + medium pole	1.8	FBCONKIT2
	Small Rectangle flag + medium pole	1.3	
	Medium Feather flag + large pole	1.4	
	Medium Teardrop flag + large pole	1.8	
Conversion kit 3	Medium Rectangle flag + large pole	1.6	FBCONKIT3



Conversion kit for small or medium flags on medium or large poles provides flag clearance above vehicle - see ground clearance in table opposite:

Note: conversion kits are suitable for use with all Flying Banner bases.

Bracket Mount Bearing Spindles (Angled, Vertical, Horizontal)



- Friction-free bearing spindle on a choice of 3 different fixing plates for vertical or horizontal mounting.
- Fixings not supplied - it is up to the installer to choose the appropriate fixing for the situation.
- Suitable for parapet walls, posts, fencing etc.

Item	Weight (kg)	Order Code
Angled	0.83	FB25DGWALBRG
Vertical	0.85	FBVERTWALBRG
Horizontal	0.7	FBCONCBRG

Note: if considering an angled mount for a shop or building frontage then we recommend use of small Teardrop Flying Banners only - to avoid flag damage against the wall in the event of wind rotation.



Ground Spike



Ground Spike Diagram

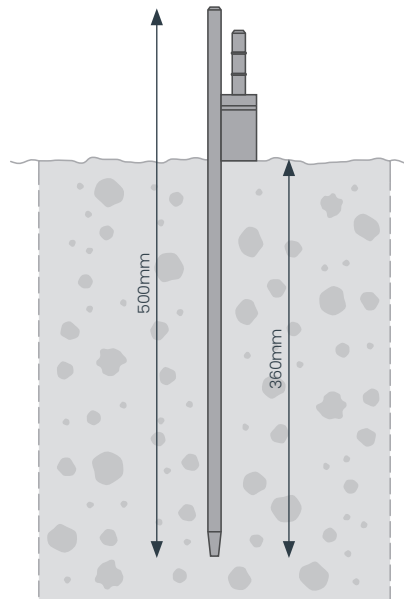

- Steel spike for soft ground or sand.
- Bearing spindle for smooth flag rotation.
- Male pole connections with O-rings provide a perfect and secure fit as well as offering free rotation to deflect wind loading.

Weight (kg)	Order Code
12	FBSPIKE(2)



Concrete Base



- Heavy duty 67kg base solution – ideal for semi-permanent positioning.
- High quality low friction bearing spindle for smooth flag rotation.
- Spindle assembly comes with 4 bolts and spanner (concrete base pre-threaded).
- Lever points provided for ease of movement.
- Due to weight of base, pallet delivery is necessary.

Item	O/A Dimensions (w x h x d mm)	Weight (kg)	Order Code
Concrete base with Bearing Spindle	600 (dia.) x 100 (h)	67	FBCONC + FBCONCBRG

Base Plate



- Stylish low profile base for interior use only eg. exhibitions, retail, malls, showrooms, sport and leisure venues.
- Matt black non reflective base finish.
- Integral spigot grip-feature holds pole/flag position and desired best line of view.
- Low profile – Base Plate sits just 9mm above floor.
- 3mm thick foam foot pads protect floor and ease lifting.
- 2 sizes: Small Base Plate for all small flags and Large Base Plate for all medium and large flags.
- Allen Key tool included to fix spigot to base.

Item	O/A Dimensions (w x h x d mm)	Weight (kg)	Order Code
Small Base Plate	300 x 300 x 9 (plate 6mm thick)	4.2	FBBASEPLATESM
Large Base Plate	400 x 400 x 9 (plate 6mm thick)	7.3	FBBASEPLATELG

Cross Base and Water Bag



- A traditional Flying Banner base solution for hard ground indoors or out.
- Compact packing can make this a popular choice when transport space to an event is at a premium.
- Powder coated grey steel cross base, with high quality low friction bearing spindle for smooth flag rotation.
- Holes at end of feet for pegging to soft ground if required (pegs not supplied).
- Optional water bag for added stability.

Item	O/A Dimensions (w x h x d mm)	Weight (kg)	Order Code
Cross Base	Length: 840 Width: 60	4	FBBASE(2)
Water Bag	540 diameter	Empty: 0.4 Full: 10.6	FBBAG(H)

Giant Pole

5.4m high attention grabbing outdoor display.

Instruction Video

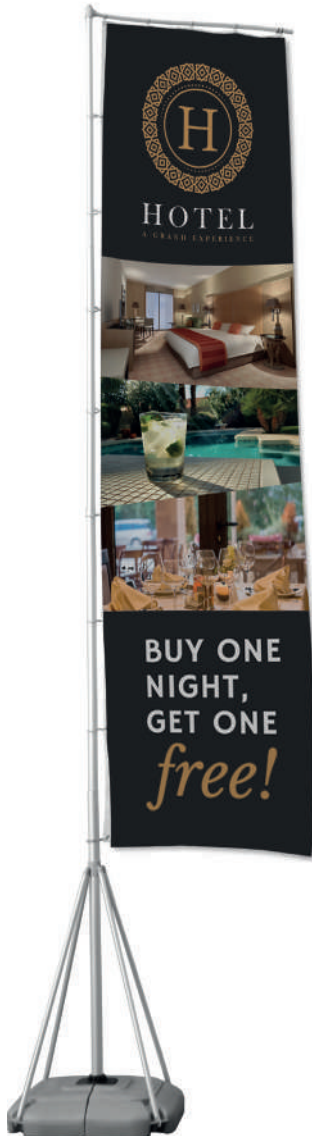

- High impact display for 1.1 x 4.1m textile flag.
- Ideal for forecourts, shopping centres, exhibitions and events.
- 2-part water fillable polyethylene base for optimum stability.
- Telescopic aluminium pole with silver anodised finish (54mm diameter at base).
- Printed flags available to order (single and double sided).
- Printed by dye sublimation – see page 191 for more details.
- Pole and base carry bags included.

Double Sided Flags

A twin layer of standard polyester fabric with central liner allows different designs on each side and a good level of opacity. Due to the added weight, double sided flags will not flutter in the wind in the same way as standard flags.

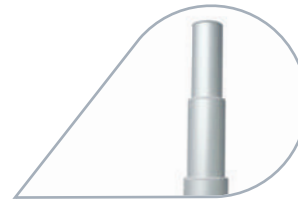
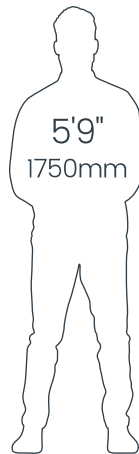

Telescopic pole.



360° rotating flag arm.



2 part base for ease of transportation.



Water fillable base with clip-in leg fixings.

Item	O/A Dimensions (w x h x d mm)	Weight (kg) Empty/Full	Availability	Order Code
Giant Pole hardware (exc. Flag)	Base: 800 x 180 x 800 O/A height: 5.4m	15/70	In stock	GIANTPOLE(H)
Printed Flag Single Sided	1100 x 4100	–	Made to order	GIANTBANNERSS(SW)
Printed Flag Double Sided	1100 x 4100	–	Made to order	GIANTBANNERDS(SW)



Recyclable: aluminium pole, polyethylene base

Adfresco® Café Barrier

Patent No. 2472843

Advertise and manage space simultaneously.

Manufactured to our patented design and quality standards, the Adfresco® Café Barrier range combines style, market leading features and performance at an attractive price.

In a choice of styles, sizes and finishes it includes the lower specification Adfresco® LT pole and base to cater for the tighter budget or for indoor/sheltered outdoor use.



Stylish, strong and effective – Adfresco® Café Barriers create the perfect space for your customers and brand. Available in polished Stainless Steel or Satin Black.



Stainless Steel showing lower cross rail and sliding ring tether option.

Cross Rail Option
Instruction Video



Bungee Option
Instruction Video



- Premium 3 series polished stainless steel for optimum outdoor life and scratch resistance or tough satin black pole and base for an alternative look.
- 13.5kg x 360mm diameter base provides excellent stability.
- Rubber edged base prevents damage to floors and gives the option to roll rather than lift.
- Option of bottom cross rail for full Equality Act compliance or lower cost bungee tether.
- Flat packed for easy storage and transport.
- Easy to assemble. Spanner included.
- Stainless steel cross rails.
- Choice of banner sizes and materials.

Satin black pole.



Lower cost LT Base and Pole.

- Lower cost and lower performance hardware option.
- 2 series polished stainless steel pole and base.
- Lighter 10.3kg x 360mm diameter base.
- Bottom bungee tether option only.
- Easy to assemble. Spanner included.
- Same choice of high quality banners.

Unique features of Adfresco® Café Barrier:

Designed for easy end of life recycling.

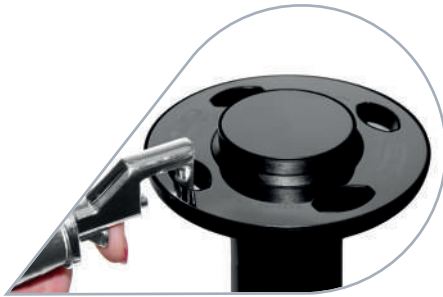

Top/Clip

- Sleek top designed for comfortable lifting, comes with quick release cross rails.
- Supplied with a protective cover to prevent damage in transit.



Adfresco® Sliding Ring

- Unique patented smooth-glide ring allows banner to flex and eliminates wind damage associated with traditional designs.
- Not available with LT.

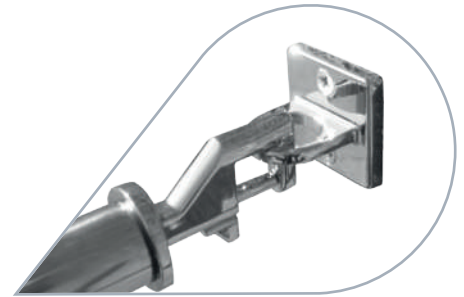

Chrome Plated Eye Plate

- For screw fixing to vertical wall or raised planter.



Adfresco® Base

- Concrete filled 13.5kg rubber edged base provides optimum stability, prevents damage to floors and gives the option to roll rather than lift.



Bottom Cross Rail

- Optional rigid lower cross rail provides audible tap for visually impaired (Equality Act Compliant).
- Not available with LT.



Bungee Connector

- Optional lower bungee connector holds banner taut – a cost effective alternative to a bottom cross rail.
- Prevents over stretching of banner.



Recyclable: stainless steel stanchion, base covers, stainless steel cross bars

Adfresco® Cafe Barrier - Selection Tool

Adfresco® allows you to individually select the elements to create your perfect Café Barrier - all with market leading features and benefits.

Choose your poles & bases:

Premium Adfresco® stainless steel



Optimum outdoor life and scratch resistance.

Premium Adfresco® satin black



A popular alternative to stainless steel.

Budget Adfresco® LT



Reduced specification. Stainless steel and lower bungee tether only.

OR

OR

Choose your lower tethering method:

Double cross-rail option

Provides strength, tautness and Equality Act compliance.

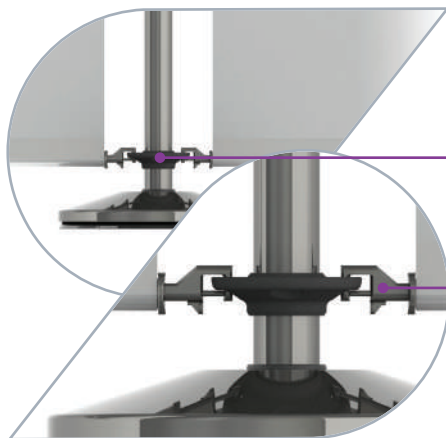

Sliding ring

Lower cross rail & clip

OR

Single cross rail and lower bungee option

Select the bungee pole connector and bungees instead of a second cross rail.

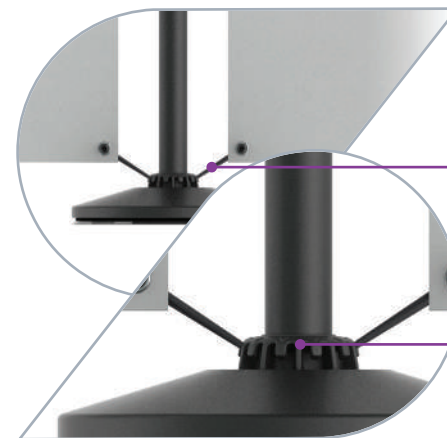

Bungee

Bungee connector

Choose your banner width:

For more exposed locations, such as seafront cafés, shorter banner widths work best.

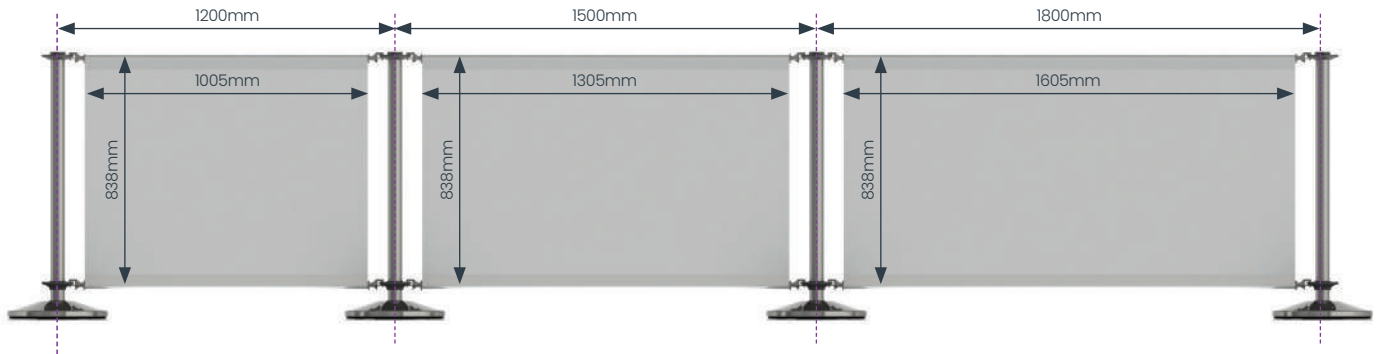

Choose your banner material:

Light Block PVC 750gsm



Reinforced and totally opaque, this is perfect for double sided print, long outdoor life and vibrant colour reproduction. The easy wipe clean surface makes it ideal for front of house food and drink environments.

Polyester Canvas 300gsm



This close weave 100% polyester fabric has all the appearance, weight and feel of a traditional canvas yet, unlike cotton based canvases, it is cost effective and will not rot or stain. Available full colour printed to one side with the option of white or single colour on the reverse.

Mesh PVC 380gsm

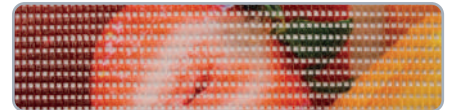

Provides a semi transparent finish and allows some air to pass through making it ideal for windy locations & subtle branding. Full colour print is available on one side (white on reverse).

All of our banners are suitable for outdoor use. To maintain best appearance, occasionally sponge down with warm soapy water. Use ratio: 30ml liquid soap / 10 litres water.

Adfresco® Example Layout

1. 12 poles/bases & 10 cross rails.

2. 10 poles/bases, 2 wall hooks/eye plates & 10 cross rails.

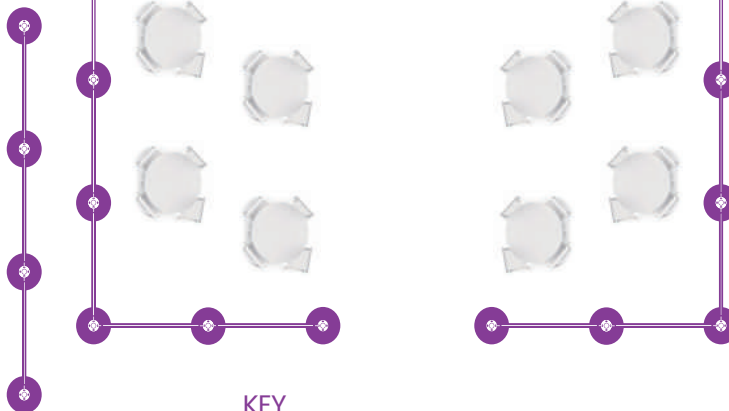
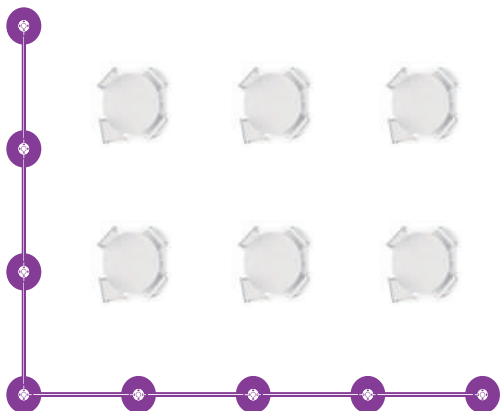

KEY



Adfresco® Base & Pole



Adfresco® Cross Rail & Banner

Choose your Adfresco® hardware:

Item	Dimensions (mm)	Weight (kg)	Order Code
Premium Stainless Steel Pole and Top Ring	Diameter: 113 (Pole Dia. 51mm) Height: 881	1.0	CBBPOLE-SS
Premium Black Steel Pole and Top Ring	Diameter: 113 (Pole Dia. 51mm) Height: 881	1.5	CBBPOLE-BLK
Budget LT Steel Pole and Top Ring	Diameter: 100 (Pole Dia. 51mm) Height: 881	1.0	CBBPOLE-201
Premium Stainless Steel Base	Diameter: 360 Height: 66	13.5	CBBBASE-SS
Premium Black Base	Diameter: 360 Height: 66	13.5	CBBBASE-BLK
Budget LT Base	Diameter: 360 Height: 45	10.3	CBBBASE-201
Cross Rail (width refers to distance between pole centres)	Width: 1200	0.8	CBBCLIP-2 + CBBCROSSBAR-2
	Width: 1500	1.1	CBBBARI500-2 + CBBCROSSBAR-2
	Width: 1800	1.2	CBBBARI800-2 + CBBCROSSBAR-2
Sliding Ring	Diameter: 110 Height: 30	0.3	CBBRING
Bungee Pole Connector	Diameter: 94 Height: 26	0.1	CBBBUNGCON
Bungee	Overall length: 100	0.01	CBBBUNGEE2
Eye Plate	40 x 40 x 35 (w x h x d)	0.06	CBBEYEPLATE
Bungee Wall Hook	Diameter: 40	0.06	CBBHOOKPLATE

Classic Garden Parasol

UK Design Registration No. 6083532

The introduction of our Classic Garden Parasol, sometimes referred to as a Pub Parasol or Beach Umbrella, marked a return of the famous Hoyland Fox brand to the UK market, a name reflecting over 175 years of dedication to the manufacture of high quality umbrella frames.



Tough, rot and weather resistant polyester fabric canopy.

Telescopic 22/25mm diameter steel pole with simple cam-clamp lever to adjust height.

No moving steel or metal parts – free of corrosion risk and moving parts not functioning properly.

Optional 20 litre white water-fillable base.



Top finial.

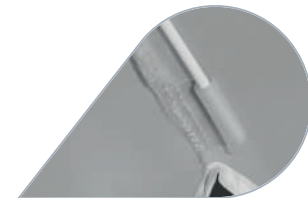

Rib tip retainer, stitching detail and valance hem.



Cam-clamp lever.



Ergonomic runner hub and release button.



Ball and socket joint for 360 degree tilt direction – position the canopy to suit any sun angle without having to rotate the whole parasol.



Slider revealing ball and socket joint.



360 degree tilt direction.

Combined with a high specification canopy fabric and our printing expertise, the result is a unique parasol product that raises the bar in terms of quality and value for money.

- 1.8m (max open) diameter, 8k (8 rib) steel wire Hoyland Fox frame.
- 3.8mm diameter high tensile, hardened and tempered, carbon spring steel ribs and stretchers.
- Telescopic 22/25mm diameter steel pole with simple cam-clamp lever to adjust height.
- All steelwork zinc phosphate pre-treated before satin white polyester powder coating.
- Unique tilt feature offering shade wherever sun is angled.
- Sliding tilt protector (slider) locks canopy in horizontal position and stops unwanted tilting due to wind or tampering.
- 180gsm PA (acrylic) coated polyester fabric canopy – tough, rot and weather resistant.
- Vibrant printing from single colour repeat logos to one full colour design covering the whole canopy – minimum 1 year outdoor life in UK.
- Optional 20 litre white PE water-fillable base – alternatively fill with kiln-dried sand for additional weight.
- No minimum order quantity.

Product	Display Area (mm)	O/A Dimensions (w x h x d mm)	Weight (kg)	Order Code
Parasol Frame & Canopy	Diameter: 1800mm	Max: 1800 x 2200 x 1800	2.6	PARAFRAME
Parasol Frame	Diameter: 1800mm	Max: 1800 x 2200 x 1800	1.9	PARAFRAME(ONLY)

Product	O/A Dimensions (w x h x d mm)	Weight (kg)			Order Code
		Empty	Water-filled	Sand-filled	
Parasol Base	440 x 150 x 440	126	18.5kg	29kg	PARABASE



Recyclable: steel telescopic pole, canopy support runners

Signtac® Self-Adhesive Floor Graphics

A professional range of certified, fire and slip-rated floor-graphic products to suit a variety of indoor and outdoor applications. No minimum order quantity.



Range overview (see table opposite for full details and comparison):

Signtac® 6 Indoor (PVC)

- Short term (up to 6 months durability), indoor only.
- Specifically developed for simple tool-free installation.
- Clean and quick removal within 6 months.

Signtac® 6 Indoor (PET)

- Short term (up to 6 month durability), PVC free, indoor only.
- Easy to apply and dimensionally stable.
- Repositionable whilst installing.

Signtac® 12 Indoor

- 2-part laminated for longer term (up to 12 months), indoor only.
- Removable, non-damaging adhesive.
- Ideal for mid to heavy foot traffic areas.

Signtac® 12 Outdoor SS

- 2-part laminated for longer term (up to 12 months), outdoor or indoor.
- Aggressive adhesive suitable for low-energy surfaces and ideal for smooth concrete outdoors.

Signtac® 12 Outdoor RS

- Longer term (up to 12 months), outdoor.
- For rough surfaces such as brick, concrete, asphalt, etc.
- Easy to apply, does not shrink and 100% recyclable.



Standard shapes and sizes:

Circles – 100mm, 200mm and 300mm dia.

Square – 100mm, 200mm and 300mm sq.

Triangles – 100mm, 200mm and 300mm sides.

Non-standard shapes and sizes:

Cut to shape within standard poster sizes A4, A3, A2, A1 and A0 and within 100/200/300mm squares.

Note – for optimum adhesion and safety, sharp corners and intricate cut detail in designs should be avoided.

		Indoor			Indoor & Outdoor	
		One Part	One Part	Two Part (laminated)	Two Part (laminated)	One Part
Product		Sigtac® 6 Indoor (PVC)	Sigtac® 6 Indoor (PET)	Sigtac® 12 Indoor	Sigtac® 12 Outdoor SS	Sigtac® 12 Outdoor RS
Description		200mic monomeric PVC film	170mic PET film	Vinyl: 90mic white monomeric PVC Laminate: 100mic matt pebble textured monomeric PVC	Vinyl: 80mic white polymeric PVC Laminate: 100mic matt pebble textured monomeric PVC	250mic white aluminium film
		Fire and slip-rated floor graphics for public spaces	Fire and slip-rated PVC-free floor graphic material	Slip-rated combination designed for floor graphic use on a variety of surfaces	Fire and slip-rated combination designed for floor graphic use on a variety of smooth outdoor surfaces	Fire and slip-rated floor graphic engineered for rough outdoor floor surfaces
Applications		Indoor carpets (low pile), indoor tiles, indoor hardwood, sealed concrete, sealed wood, waxed vinyl, marble, terrazzo			Indoor/outdoor smooth concrete and brick	Outdoor tarmac, stone, marble, ceramic tiles, paving slabs, indoor/outdoor concrete, brick
Adhesive		Removable	Removable	Removable	Permanent	Permanent
Slip Ratings	Pendulum Test Method	Low slip potential 40 PTV	Low slip potential 38 PTV	Low slip potential 36 PTV	Low slip potential 36 PTV	Low slip potential 72 PTV
	Ramp Test	R10	R10	R11	R11	R12
Fire Ratings		BI	Bfl – s1	Fire ratings not available	Combined Bfl – s1	Bfl – s1
Durability Dependent upon proper installation and foot traffic.		Short term up to 6 months indoor	Short term up to 6 months indoor	Long term up to 12 months indoor	Long term up to 12 months outdoor	Long term up to 12 months outdoor



JUST EAT

Outdoor (Indoor) Wall/Window Mounted

We have some excellent secondary signage, chalkboard and poster display solutions available for wall or window mounting with weather resistant properties suitable for outdoor use.

Projecting 'flag' or 'bus-stop' advertising, to attract attention at eye-level and above, is available in the form of permanent Projecting Flange Signs, or, as more temporary wall or window-mounted Display Flags that can be taken in at night or when the premises are closed. They are designed to provide elevated visibility and are a good alternative to a pavement sign when there isn't space on the pavement, or of course to complement a pavement sign that is designed to catch the eye at street level.

Our Poster Frames, Noticeboards and Menu Cases range includes low voltage LED illuminated options. It also includes a world beating range of Snapframes, the widely popular front opening aluminium poster frame that wins on price and functionality. As significant developers and manufacturers of the Snapframe since our first frame designs in 1990 we have been instrumental in bringing refinement, value engineering and supplementary patented innovation to the market ever since.

Dealer/Stockist Signs

Permanent brand presence at dealers and stockists.



Permanent brand signage at a stockist or dealers premises is a win-win, free advertising for the brand whilst the 'premium' brand endorsement will draw customers to the stockist. Long lasting, bold, vibrant print is the order of the day and that's our business!

- Premium options in aluminium, acrylic, polycarbonate or ACM.
- Screen print option and/or varnish over-print for extended outdoor life.
- Can be any size or shape pre-drilled for wall fixing.
- Stand-off fixing option for added prestige.
- Low-cost shorter outdoor life options in foam PVC or polypropylene ('Correx') - ideal for estate agent boards.
- No minimum order quantity.

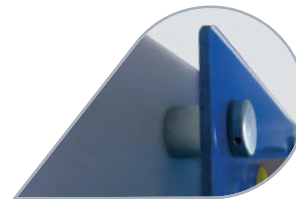

Optional stand-off sign fixings.



Recyclable: panel material dependant



When it comes to standing out at the point of purchase the combination of material choice, shape and cool printing effects can make a real difference.

Flavour/Range Boards



- Printed steel wall panel with set of interchangeable magnetic flavour labels.
- High promotional and functional value at the point of sale.
- Replacement magnetic labels can be purchased separately at a later date if required.



Snapframes (overview)

 Fully Recyclable



Anti-glare cover sheet included.

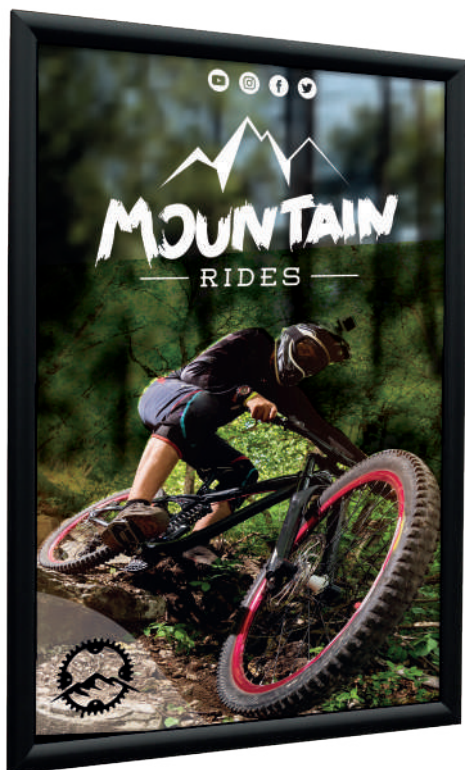

All our Snapframes feature:

- Easy snap-open/snap-shut poster change.
- Built-in security – when closed all fixings and opening method are hidden from view.
- UV stable poster cover sheet – will not turn brown and protects poster from fade in sunlight.
- Anti-glare poster cover sheet – maintains message visibility under bright lighting.
- Pre-drilled and individually boxed with screws and wall plugs.
- Suitable for outdoor use.

Note: wider frame profiles do a better job of keeping the poster cover and poster secure in windy weather than smaller frame profiles.

Express make-to-order service from a choice of 12 stock finishes

- No minimum order quantity.
- Fast lead times – typically, 1-10 frames (3-5 days), 11-25 frames (5-7 days).
- Custom sizes from as small as 210 x 210mm.
- Oversize frames (>1.5m²) may require collecting by customer if too large for our parcel delivery provider or for palletising.
- Choose from the following stock colours and finishes:



Silver anodised
(in stock)
15, 25 or 38mm
standard and
25mm or 42mm
security.



Signal White*
RAL 9003
(25 & 38mm)



Jet Black*
RAL 9005
(25 & 38mm)



Dusty Grey
RAL 7037
(25 & 38mm)

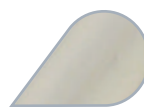

Satin Chrome
(25mm)
Bright Chrome
(38mm)



Stainless Steel
(25mm only)



Moss Green
RAL 6005
(25 & 38mm)

* Standard sizes in stock – see pages 73-75

Other colours available subject to minimum order quantity and longer lead time.



Traffic Red
RAL 3020
(25 & 38mm)



Ultramarine Blue
RAL 5002
(25 & 38mm)



Sapphire Blue
RAL 5003
(25 & 38mm)

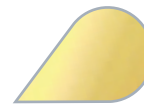

Gold
(25mm only)



Wood
(25mm only)

Standard Snapframes

Quick and easy poster display for indoor and outdoor use.



15mm Profile with Mitred Corners – Silver

Poster Size	Display Area (mm)	O/A Dimensions (w x h mm)	Weight (kg)	Availability	Order Code
A5	130 x 190	160 x 220	0.16	In stock	SNA515SA(P)
A4	195 x 280	225 x 310	0.23	In stock	SNA415SA(P)
A3	277 x 400	307 x 430	0.34	In stock	SNA315SA(P)
A2	420 x 594	430 x 604	0.87	Made to order	SNA215SA(M)
20" x 30"	508 x 762	518 x 772	1.65	Made to order	SN2315SA(M)
A1	594 x 841	604 x 851	1.62	Made to order	SNA115SA(M)

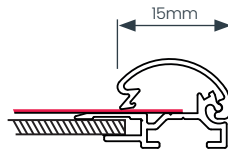

15mm Profile with Mitred Corners – Black

Poster Size	Display Area (mm)	O/A Dimensions (w x h mm)	Weight (kg)	Availability	Order Code
A5	127 x 188	158 x 220	0.16	In stock	SNA515BLK(P)



25mm Profile with Round Corners – Silver

Poster Size	Display Area (mm)	O/A Dimensions (w x h mm)	Weight (kg)	Availability	Order Code
A5	148 x 210	178 x 240	0.31	Made to order	SNRA525SA(M)
A4	195 x 282	245 x 333	0.28	In stock	SNRA425SA(P)
A3	275 x 400	325 x 450	0.44	In stock	SNRA325SA(P)
A2	405 x 580	455 x 630	0.70	In stock	SNRA225SA(P)
20" x 30"	492 x 745	545 x 797	0.96	In stock	SNR2325SA(P)
A1	574 x 821	624 x 870	1.3	In stock	SNRA125SA(P)
30" x 40"	762 x 1016	792 x 1046	2.75	Made to order	SNR3425SA(M)
A0	841 x 1189	871 x 1219	3.75	Made to order	SNRA025SA(M)
40" x 60"	1016 x 1524	1046 x 1554	4.8	Made to order	SNR4625SA(M)

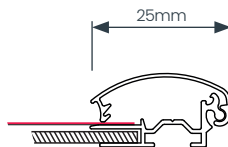

Standard Snapframes

Quick and easy poster display for indoor and outdoor use.



25mm Profile with Mitred Corners - Silver

Poster Size	Display Area (mm)	O/A Dimensions (w x h mm)	Weight (kg)	Availability	Order Code
A5	148 x 210	178 x 240	0.31	Made to order	SNA525SA(M)
A4	190 x 277	240 x 325	0.28	In stock	SNA425SA(P)
A3	275 x 399	327 x 448	0.44	In stock	SNA325SA(P)
A2	400 x 575	450 x 625	0.71	In stock	SNA225SA(P)
495 x 708mm	477 x 690	528 x 740	0.80	In stock	SN49570825SA(W)
20" x 30"	492 x 746	544 x 797	0.97	In stock	SN2325SA(P)
A1	576 x 825	627 x 875	1.0	In stock	SNA125SA(P)
30" x 40"	762 x 1016	792 x 1046	2.75	Made to order	SN3425SA(M)
A0	824 x 1172	876 x 1222	1.74	In stock	SNA025SA(W)
40" x 60"	1016 x 1524	1046 x 1554	4.8	Made to order	SN4625SA(M)

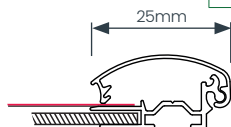

25mm Profile with Mitred Corners - Black

Poster Size	Display Area (mm)	O/A Dimensions (w x h mm)	Weight (kg)	Availability	Order Code
A4	190 x 277	240 x 325	0.28	In stock	SNA425BLK(P)
A3	275 x 399	327 x 448	0.44	In stock	SNA325BLK(P)
A2	400 x 575	450 x 625	0.71	In stock	SNA225BLK(P)
20" x 30"	492 x 746	544 x 797	0.97	In stock	SN2325BLK(P)
A1	576 x 825	627 x 875	1.0	In stock	SNA125BLK(P)
A0	821 x 1169	875 x 1223	1.87	In stock	SNA025BLK(W)

25mm Profile with Mitred Corners - White

Poster Size	Display Area (mm)	O/A Dimensions (w x h mm)	Weight (kg)	Availability	Order Code
A4	190 x 277	240 x 325	0.28	In stock	SNA425WT(P)
A3	275 x 399	327 x 448	0.44	In stock	SNA325WT(P)
A2	400 x 575	450 x 625	0.71	In stock	SNA225WT(P)
20" x 30"	492 x 746	544 x 797	0.97	In stock	SN2325WT(P)
A1	576 x 825	627 x 875	1.0	In stock	SNA125WT(P)

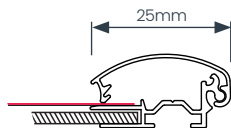

Standard Snapframes

Quick and easy poster display for indoor and outdoor use.

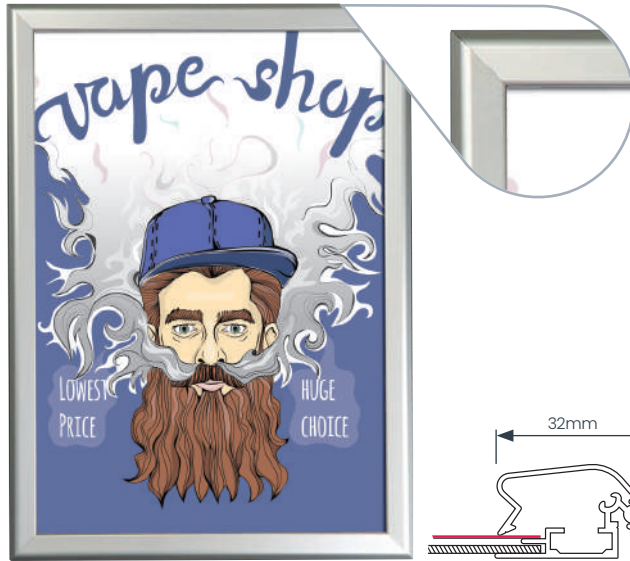

32mm Profile with Mitred Corners - Silver

Poster Size	Display Area (mm)	O/A Dimensions (w x h mm)	Weight (kg)	Availability	Order Code
A4	190 x 280	255 x 340	0.47	In stock	SNA432SA(W)
A3	275 x 400	340 x 465	0.67	In stock	SNA332SA(W)
A2	400 x 575	465 x 640	0.96	In stock	SNA232SA(W)
20" x 30"	490 x 745	550 x 805	1.22	In stock	SN203032SA(W)
A1	575 x 820	635 x 885	1.45	In stock	SNA132SA(W)
30" x 40"	740 x 995	805 x 1060	2.0	In stock	SN304032SA(W)
A0	820 x 1170	880 x 1230	2.5	In stock	SNA032SA(W)
40" x 60"	995 x 1505	1055 x 1565	3.0	In stock	SN406032SA(W)

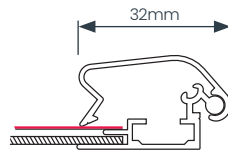

Also available with round corners (made to order).

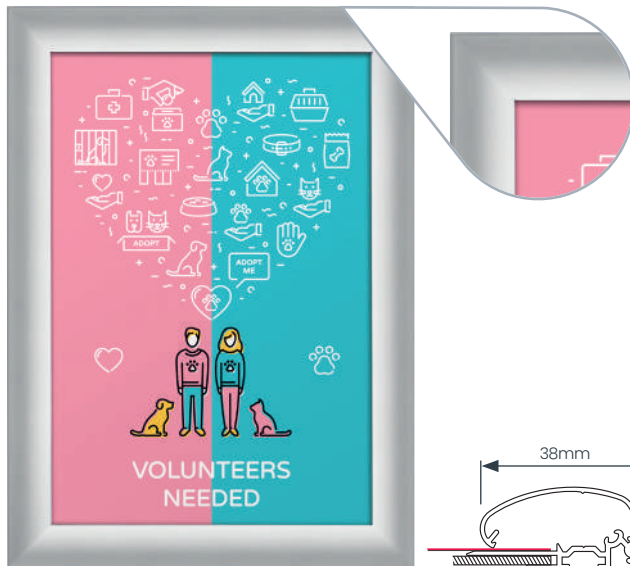

38mm Profile with Mitred Corners - Silver

Poster Size	Display Area (mm)	O/A Dimensions (w x h mm)	Weight (kg)	Availability	Order Code
A3	297 x 420	342 x 465	0.8	Made to order	SNA338SA(M)
A2	420 x 594	465 x 639	1.4	Made to order	SNA238SA(M)
20" x 30"	508 x 762	553 x 807	1.6	Made to order	SN2338SA(M)
A1	594 x 841	639 x 886	2.5	Made to order	SNA138SA(M)
30" x 40"	725 x 980	800 x 1050	2.0	In stock	SN3438SA(W)
A0	805 x 1154	888 x 1230	2.5	In stock	SNA038SA(W)
40" x 60"	980 x 1490	1060 x 1570	3.5	In stock	SN4638SA(W)

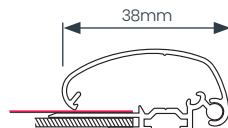

Security Snapframes

Virtually impossible to open by hand.



Fully Recyclable



Hand-held opening tool.

- Easily opened by our hand-held opening tool (sold separately).
- Available in 2 profile sizes (25mm and 42mm).
- Supplied with anti-glare poster cover sheet for clear poster display.
- Pre-drilled and individually boxed with screws and wall plugs.
- Increased frame tension in Security frames can offer improved resistance to poster cover loss in windy situations.
- Silver anodised finish as standard – 25mm profile available in almost any RAL colour through our bespoke snapframe service.
- Ideal for schools, colleges and spaces at risk of unwanted tampering.

25mm Profile with Mitred Corners

Poster Size	Display Area (mm)	O/A Dimensions (w x h mm)	Weight (kg)	Availability	Order Code
A4	195 x 282	245 x 332	0.34	In stock	SNSA425SA(W)
A3	282 x 405	332 x 450	0.5	In stock	SNSA325SA(W)
A2	405 x 578	455 x 630	0.75	In stock	SNSA225SA(W)
20" x 30"	493 x 745	543 x 796	1.0	In stock	SNS2325SA(W)
A1	577 x 825	628 x 875	1.2	In stock	SNSA125SA(W)
30" x 40"	762 x 1016	792 x 1046	2.75	Made to order	SNS3425SA(M)
A0	841 x 1189	871 x 1219	3.75	Made to order	SNSA025SA(M)
40" x 60"	1016 x 1524	1046 x 1554	4.8	Made to order	SNS4625SA(M)

42mm Profile with Mitred Corners

Poster Size	Display Area (mm)	O/A Dimensions (w x h mm)	Weight (kg)	Availability	Order Code
A3	297 x 420	240 x 463	0.89	Made to order	SNSA342SA(M)
A2	420 x 594	463 x 637	1.57	Made to order	SNSA242SA(M)
20" x 30"	508 x 762	551 x 805	1.9	Made to order	SNS2342SA(M)
A1	594 x 841	637 x 884	2.2	Made to order	SNSA142SA(M)
30" x 40"	722 x 977	807 x 1065	3.5	In stock	SNS3442SA
A0	800 x 1147	890 x 1230	4.0	In stock	SNSA042SA
40" x 60"	975 x 1482	1060 x 1565	6	In stock	SNS4642SA

Lockable Snapframes

For optimum poster security.



- Opens via simple Allen Key operation (included).
- Sides open sequentially for added security.
- Ideal for unmonitored locations.
- Available in 32mm profile.
- Supplied with anti-glare poster cover sheet for clear poster display.
- Pre-drilled and individually boxed with screws and wall plugs.
- Suitable for indoor and outdoor use.
- Silver anodised finish as standard, customisable if required.

32mm Profile with Mitred Corners

Poster Size	Display Area (mm)	O/A Dimensions (w x h x d mm)	Weight (kg)	Order Code
A4	190 x 280	255 x 340	0.56	SNLKA432SA(W)
A3	280 x 402	345 x 465	0.75	SNLKA332SA(W)
A2	400 x 575	464 x 640	1.1	SNLKA232SA(W)
495 x 708	475 x 690	540 x 750	1.3	SNLK49570832SA(W)
20" x 30"	490 x 742	552 x 805	1.4	SNLK203032SA(W)
A1	575 x 822	640 x 885	1.62	SNLKA132SA(W)
30" x 40"	740 x 997	805 x 1058	2	SNLK304032SA(W)
A0	822 x 1170	885 x 1230	2.5	SNLKA032SA(W)
40" x 60"	1000 x 1505	1057 x 1565	3.5	SNLK406032SA(W)



Easy to insert and change poster.



Opens via simple Allen key operation.

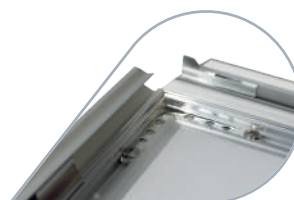

Sequentially closing sides.

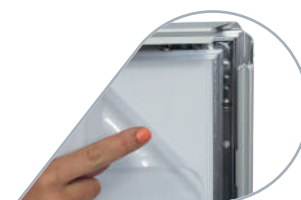

Anti-glare cover sheet included.

Frameworkz

Patent No. 2464696

Unlike any other poster frames available, Frameworkz Snapframes can be digitally printed with almost any design.

From logos and text to images and patterns, the choice is yours and the opportunities are truly endless.

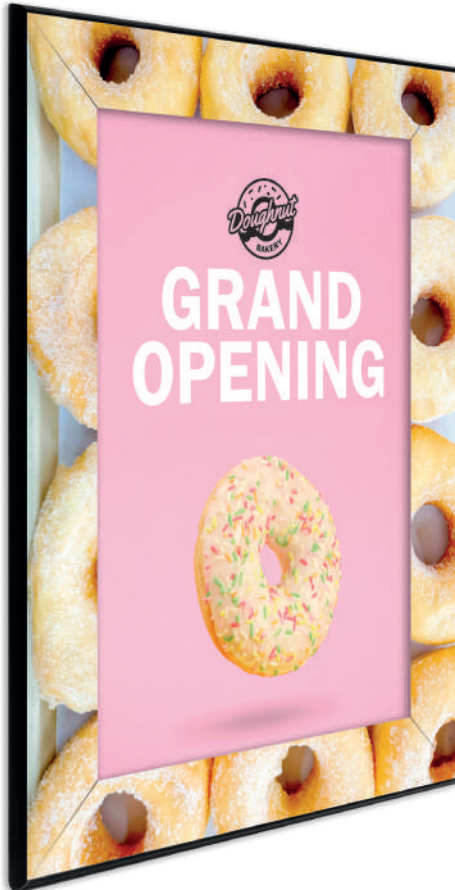

- Front opening aluminium snapframes for quick and easy poster change.
- Suitable for external use (2-3 years in temperate climates).
- Minimal distance between frame and poster allows design to cross over.
- Anti-glare 500 micron PET poster cover sheet as standard or optional 750 micron gloss clear polycarbonate at additional cost.
- Pre-drilled for wall mounting.
- Available in any frame size from A3 to 40" x 60".
- Made to order (no minimum order quantity).

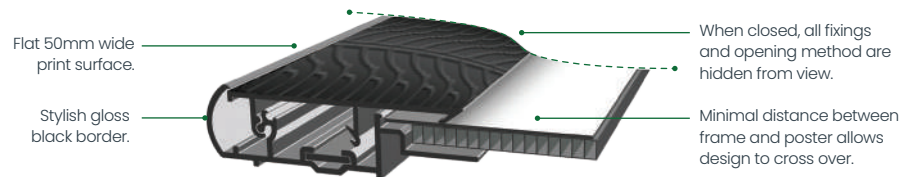

 Recyclable: aluminium frames, PET poster cover sheet, mechanical fixings

Poster Size	Display Area (mm)	O/A Dimensions (w x h x d mm)	Profile Depth (mm)
Any size from A3 to 40" x 60"	Poster -31.5	Poster +79	15

Due to frame cutting and artwork tolerances of +/- 1mm, a visible step across the mitred corners is sometimes unavoidable. Designs featuring straight lines across the corners will be particularly prone to this.

Slimlok Poster Case

Stylish poster display cases with lockable doors.

Express made to order stock colours (below) have no minimum order quantity



- 52 x 30mm profile durable aluminium frame.
- Vandal resistant 1.5mm polycarbonate glazing panel
- Internal clips hold posters securely in place and allows for quick and easy poster change.
- Ideal for outdoor use.
- Door stays supplied as standard on stock units at A1 size or larger.
- A1 size and larger have two locks.
- Other sizes are available, made to order, with or without stays (no minimum order quantity).



Each poster case supplied with a set of keys.

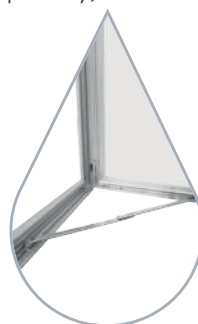

Door stays on larger sizes as standard.



Internal clips hold posters securely in place.



Signal White
RAL 9003



Dusty Grey
RAL 7037



Traffic Red
RAL 3020



Ultramarine
Blue RAL 5002



Sapphire Blue
RAL 5003



Moss Green
RAL 6005



Recyclable: aluminium frames, polycarbonate glazing panel

Poster Size	Display Area (mm)	O/A Dimensions (w x h x d mm)	Weight (kg)	Order Code (without door stays)		Order Code (with door stays)	
				Silver	Black	Silver	Black
A4	186 x 273	291 x 378 x 32	2	SKA4MK3(W)	SKA4MK3BLK	-	-
A3	273 x 396	378 x 501 x 32	2.5	SKA3MK3(W)	SKA3MK3BLK	-	-
A2	396 x 570	501 x 675 x 32	3.5	SKA2MK3(W)	SKA2MK3BLK	-	-
20" x 30"	484 x 738	589 x 843 x 32	5	SK2030MK3(W)	SK2030MK3BLK	-	-
A1	570 x 817	675 x 922 x 32	6	-	-	SKA1MK3WS(W)	SKA1MK3WSBLK
30" x 40"	738 x 992	843 x 1097 x 32	8	-	-	SK3040MK3WS(W)	SK3040MK3WSBLK
A0	817 x 1165	922 x 1270 x 32	9	-	-	SKA0MK3WS(W)	SKA0MK3WSBLK(W)
40" x 60"	992 x 1500	1097 x 1605 x 32	13	-	-	SK4060MK3WS	SK4060MK3WSBLK

Slimlok Menu Case

Featuring a magnetic back panel and dedicated header area.

Express made to order stock colours (below) have no minimum order quantity



- 52 x 30mm profile durable silver anodised aluminium frame.
- Vandal resistant 1.5mm polycarbonate glazing panel.
- Magnetic pins included.
- Not designed for landscape orientation.
- Door stays fitted as standard on 4 x A4 model.
- Each menu case supplied with a set of keys.
- Header branding in self adhesive vinyl or direct to surface print (no minimum order quantity).
- Custom sizes available (no minimum order quantity).

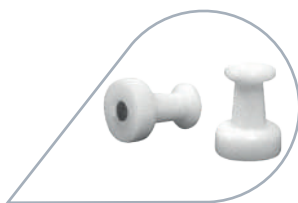

Supplied with a set of magnetic pins.

Available in 4 stock sizes

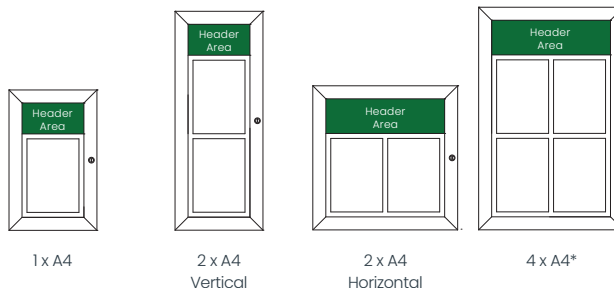

Recyclable: aluminium frames, polycarbonate glazing panel, steel back panel

O/A Dimensions (w x h x d mm)	355 x 567 x 32	355 x 884 x 32	585 x 585 x 32	585 x 899 x 32
Header Size (mm)	251 x 125	251 x 125	481 x 140	481 x 140
Approx. Weight (kg)	3	5	5	7
Order Code	SKMC1XA4MK3	SKMC2XA4VERTMK3	SKMC2XA4HORIMK3	SKMC4XA4MK3

*Door stays fitted as standard



Jet Black
RAL 9005



Signal White
RAL 9003



Dusty Grey
RAL 7037



Traffic Red
RAL 3020



Ultramarine
Blue RAL 5002



Sapphire Blue
RAL 5003



Moss Green
RAL 6005



Illuminated Slimlok Menu Case

Stylish 24 hour menu display with branded header area.

Express made to order stock colours (below) have no minimum order quantity



- 52 x 30mm durable silver anodised aluminium frame.
- Vandal resistant 1.5mm polycarbonate glazing panel.
- Magnetic pins included.
- Not designed for landscape orientation.
- Door stays fitted as standard on 4 x A4 model.
- Each menu case supplied with a set of keys.
- Header branding in self adhesive vinyl or direct to surface print (no minimum order quantity).
- 2.5m power cable with 3-pin 12V plug adaptor included.



LED strip along top inside edge.



3m waterproof extension cable available (page 201).

Available in 4 stock sizes

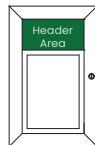

1 x A4

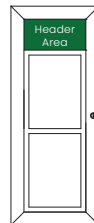

2 x A4 Vertical

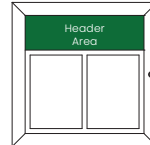

2 x A4 Horizontal

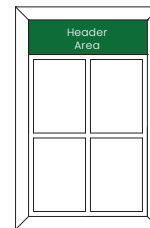

4 x A4*



Recyclable: aluminium frame, polycarbonate glazing panel, steel back panel

O/A Dimensions (w x h x d mm)	355 x 567 x 32	355 x 884 x 32	585 x 585 x 32	585 x 899 x 32
Header Size (mm)	251 x 125	251 x 125	481 x 140	481 x 140
Approx. Weight (kg)	3.5	5.5	5.5	7.5
Order Code	SKILLMC1XA4MK3	SKILLMC2XA4VMK3	SKILLMC2XA4HMK3	SKILLMC4XA4MK3

* Door stays fitted as standard.



Jet Black RAL 9005



Signal White RAL 9003



Dusty Grey RAL 7037



Traffic Red RAL 3020



Ultramarine Blue RAL 5002



Sapphire Blue RAL 5003



Moss Green RAL 6005

Slimlok Noticeboard

Stylish poster display case with lockable doors and magnetic back panel.

Express made to order stock colours (below) have no minimum order quantity



4x4 shown.



Recyclable: aluminium frames, polycarbonate glazing panel, steel back panel

- 52 x 30mm profile durable silver anodised aluminium frame.
- Vandal resistant 1.5mm polycarbonate glazing panel.
- Magnetic pins included.
- Suitable for internal or external use, portrait or landscape.
- Back panel suitable for vinyl application.
- Door stays fitted as standard on all models.
- Custom sizes available (no minimum order quantity).
- Each noticeboard supplied with a set of keys.



Durable aluminium frames.

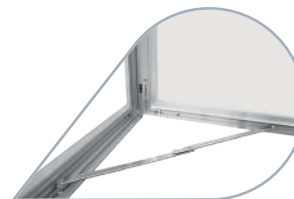

Door stays fitted as standard on all models.

Available in 4 stock sizes

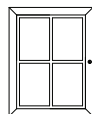

4 x A4

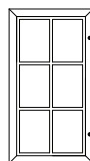

6 x A4

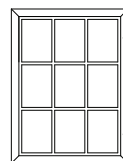

9 x A4

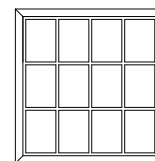

12 x A4

O/A Dimensions (w x h x d mm)	585 x 759 x 32	585 x 1076 x 32	815 x 1076 x 32	1045 x 1076 x 32
Weight (kg)	6.4	8	12	14.8
Order Code	NB4XA4MK3	NB6XA4MK3	NB9XA4MK3	NB12XA4MK3



Jet Black
RAL 9005



Signal White
RAL 9003



Dusty Grey
RAL 7037



Traffic Red
RAL 3020



Ultramarine
Blue RAL 5002



Sapphire Blue
RAL 5003



Moss Green
RAL 6005



Lockable Weatherproof Smart LEDbox

Stylish low-profile illuminated poster frame for outdoor use.



- Front opening 35mm profile silver anodised snapframe for quick and easy poster change.
- Tamper-resistant locking frame with sequential opening (Allen key included).
- Weather seal for outdoor poster protection.
- Suitable for portrait or landscape wall mounting.
- Edgelit panel provides strong, even illumination.
- White Osram LEDs emitting 6500K optimum colour temperature.
- Swivel feature offers optional rear (hidden) or side cable exit point.
- Wall fixings provided.
- CE certificate supplied with each unit.



2m power cable and power supply included.



2m internal and external (waterproof) extension cables available (page 201).



Recyclable: aluminium snapframe perimeter frame, PET poster cover, acrylic light panel

Poster Size	Display Area (mm)	O/A Dimensions (w x h x d mm)	Weight (kg)	Order Code
30" x 40"	753 x 1007	823 x 1077 x 30	13.25	EXTLED34
A0	832 x 1180	902 x 1250 x 30	15.42	EXTLEDA0
40" x 60"	1007 x 1515	1077 x 1585 x 30	24.37	EXTLED46

Hi-Sight

Registered Design No. 000879876

Instruction Video



Thanks to its unique pull down poster cartridge, the Hi-Sight has many advantages over traditional poster frames.



- Can be mounted up to 3 times higher than a regular frame.
- Poster change is quicker, easier and safer - no need to stretch or use ladders.
- Reduced risk of tampering and vandalism.
- Hard wearing aluminium frame.
- Fixed polycarbonate cover with magnetic seals, virtually no risk of poster loss.
- Excellent weather resistance.
- Available with custom coloured borders (no minimum order quantity).

Ideal for out of town retailers. Hi-Sight maximises visibility of store front promotions – vital in the drive for greater awareness and increased sales.



Apply finger pressure just above border and lift.



Poster cover security fixings.



Traditional frames – low visibility.



Hi-Sight – high visibility!

Pull down poster cartridge for safe, quick and easy poster change.

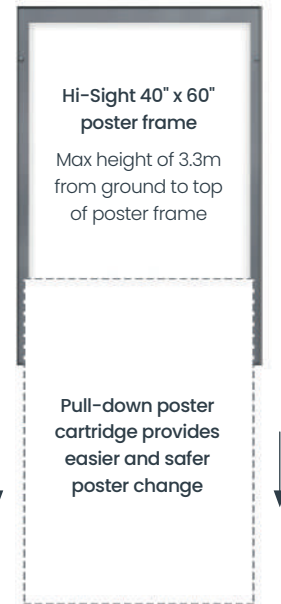
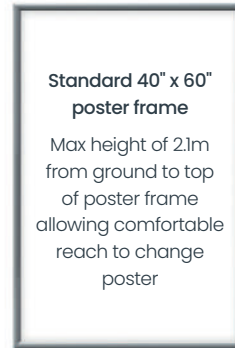
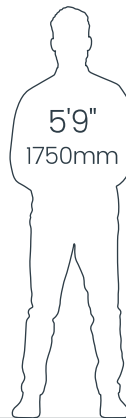

Posters are held in place by 4 pinch holders on the top of the cartridge.

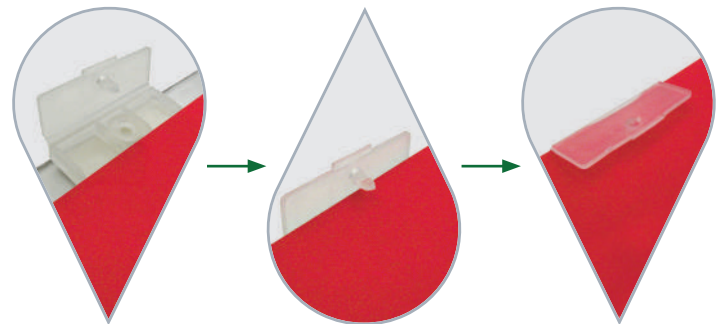

Open poster-pinch mounts to add or change posters.

Place poster within poster-pinch opening.

Close poster-pinch mounts to pierce and grip poster.



Recyclable: aluminium frames, polycarbonate poster cover

Poster Size	Display Area (mm)	O/A Dimensions (w x h x d mm)	Weight (kg)	Order Code
30" x 40"	751 x 990	858 x 1122	7.2	HIS34SA(S)
A0	830 x 1163	937 x 1295	8.4	HISA0SA(S)
40" x 60"	1005 x 1498	1112 x 1630	12	HIS46SA(S)

PVC Banner

Semi-permanent large format outdoor promotion.



- Any size up to 20m x 3m.
- Choice of 3 stock materials including a light-block for double-sided print.
- Folded welded hems provide a double strength perimeter for optimal wind load/tear resistance.
- Corrosion-free metal eyelets.
- Supplied with 300mm translucent white nylon cable ties- extremely secure, quick and easy to use to achieve the best banner appearance.
- Individually poly-bagged for protection during distribution.
- No minimum order quantity.
- See our Banner Frames opposite and on page 46.



Fully Recyclable

Front-Lit PVC 440gsm



Our most popular banner for single sided print only. Front-lit banners suit fence and wall-mounting locations.

Light Block PVC 610gsm



Our highest performing material, Light Block PVC provides excellent colour vibrancy and long lasting performance. Ideal for single or double sided print.

Mesh PVC 270/380gsm*



Perforations allow air to pass through and reduce wind loading, making it well-suited for windy locations eg. seafronts & site/event fencing.

*Subject to size/quantity.

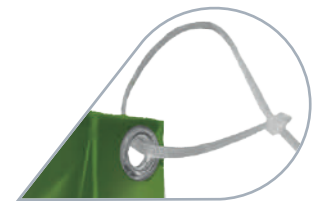

All banners supplied with tie-wraps.

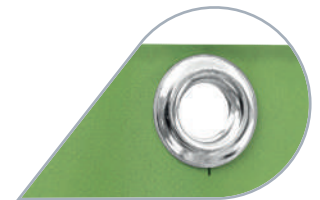

Silver finish metal eyelets.

Wall Banner Frame

Lightweight aluminium banner frame kit for wall mounting indoors or outside.



- 8x galvanised steel stand-off brackets for wall mounting.
- Aluminium 25 x 25mm frame tubes – low weight for handling and fitting.
- Fast push-fit assembly with simple installation.
- Low profile design – frame stands just 125mm forward of any mount surface.
- Self-adjusting bungee hooks hold eyeletted banners under tension.
- Bungees included.
- Recommended banner size: 2840 x 1090mm.



Wall fixing brackets.



Full bungee kit included.



Recyclable: aluminium tubes, wall brackets

Display Area (mm)	O/A Dimensions (w x h x d mm)	Weight (kg)	Order Code
2840 x 1090	3000 x 1250 x 125	5	BANFRAMEWALL

Flange Signs

Low cost, high impact flat projecting signs, available in 3 standard sizes.

Standard shapes/sizes:

Rectangular



Round



Oval



Fully Recyclable

Shape	Display Area (w x h mm)	O/A Dimensions (w x h x d mm)	Weight (kg)	Order Code
Round	495 diameter	550 x 495 x 50	0.83	FLSR1.2
Oval	500 x 400	600 x 400 x 50	0.72	FLSO1.2
Rectangular	575 x 417	575 x 417 x 50	0.91	FLSS1.2

- Cost effective, double sided shop front advertising.
- Exceptional value with 5 plus years of outdoor life.
- 1.2mm aircraft grade aluminium panels with a gloss white polyester powder coated finish – ideal for vinyl application.
- Direct to surface printing available. No minimum order quantity.
- 50mm fixing flange, pre-drilled with round fixing holes as standard.

Custom shapes/sizes:



- Customised shape can enhance stand-out and brand recognition.
- Made to order - minimum order quantity 25.



Made To Order

Sucker Flags

Visible and versatile – inside or out.



Easily adjustable angle for any situation.

Single lever secures flag and allows quick release.

- Ideal for chillers, product displays, static vehicles or windows.
- True double-sided polyester flags (not mirror image on reverse) with black pole hem.
- Simply secures to smooth surfaces such as glass, plastic or metal.
- Fibre composite pole keeps flag taut and swivels in the wind.
- Adjustable angle.
- Quick and easy to change flags for new promotions.
- Kit includes pole, bracket and flag.
- Minimum order quantity 100.

Ways to display:



Perfect for chillers and display cases



Great for forecourts and showrooms.



Also ideal for use on shop frontages.



Made To Order

Item	Display Area (w x h mm)	Dimensions (mm)	Weight (kg)
Sucker Flag Kit (complete)	233 x 501	285 x 720	0.15

Standard Flag Kit

For wall mounting.



- Tapered socket ensures excellent pole grip and prevents loss of flags in windy conditions.
- Suitable for screw fixing to walls.
- Kit includes polypropylene bracket, PVC pole, finial and collar. Flag available separately.
- Plain 750gsm reinforced light-block PVC flags held in stock. Suitable for vinyl graphics.
- Marine grade polyester stitching for optimum flag life.
- Print service available (no minimum order quantity).
- Custom shaped flags available (minimum order quantity 25).



Bracket



Recyclable: polypropylene bracket, PVC pole, polypropylene collar and finial, PVC flag

Item	Dimensions (mm)	Weight (kg)	Order Code
Standard Flag Kit (bracket, pole, finial and collar)	Bracket: 50 (w) x 117 (h) Pole: 750 (length) x 19 (dia.)	0.2	FLKIT
Display Flag	430 x 355 x 560	0.2	FLAGTRADE

Noscrewz Flag Kit

Ideal for glass mounting.

Patent No. 2443417
Instruction Video



- Safe, tamper proof and secures on any smooth surface.
- Incredibly quick and easy to use, simply push onto surface and twist. No tools required.
- Kits include bracket, sectional pole offering variable length, collar and finial. Flag available separately.
- Suitable for internal and external use.
- Plain 750gsm reinforced light-block PVC flags held in stock. Suitable for vinyl graphics.
- Print service available (no minimum order quantity).
- Custom shaped flags available (minimum order quantity 25)*.



A simple twist creates a vacuum that locks the bracket in place.

   **Recyclable:** PVC/ASA bracket, PVC pole, polypropylene collar and finial, PVC flag

Item	Dimensions (mm)	Weight (kg)	Order Code
Noscrewz Flag Kit (bracket, pole, finial and collar)	Bracket: 90 (w) x 150 (h) Pole length: 150/300/450/600/750 Pole diameter: 19	0.4	NOSCREWZ2
Display Flag	430 x 355 x 560	0.2	FLAGTRADE

* Care is required if using Noscrewz for oversized (wider and/or taller) flags. Unless the pole is shortened (use of fewer pole sections during assembly) we would only recommend flags in our standard 750gsm reinforced light block PVC up to a maximum of 0.25m² (less than 200g in weight).



Simply twist back and pull upper or lower tab to release bracket.

Teardrop Flying Banner (on Angled Wall Bracket)



A great way to pack a promotional punch at the store front if pavement or forecourt space is at a premium, or if you just want to do something different and impactful above head height.

- Small Teardrop Flying Banner in standard or airmesh polyester textile supported on a sectional carbon composite pole.
- 2m long flag and rotational movement for eye-catching long range outdoor promotion.
- Angled Bracket Mount Bearing Spindle offers friction-free flag rotation and secure flag retention, whilst being easy to detach the pole and flag when premises are closed.
- For additional product information see Flying Banners on page 48.

Item	Weight (kg)	Size (mm)	Order Code
Pole & Bag	1	-	FBTSM
Angled Bracket Mount Bearing Spindle	0.83	-	FB25DGWALBRG
Printed flag with wrap-around printed pole sleeve	-	771 x 2060	FBTSMBAN(SW)
Printed flag with reinforced elasticated black pole sleeve	-	800 x 1992	FBTSMBANBEH(SW)
Printed flag with reinforced elasticated white pole sleeve	-	800 x 1992	FBTSMBANWEH(SW)

Our Chalkboard Panels



The last thing customers want is a chalkboard that requires repainting regularly and warps and disintegrates if used outdoors. Sadly there are too many inferior products on the market that do just that – even when advertised for outdoor use!

Our high-quality board materials:

- Are maintenance-free and never need repainting.
- Are easy to clean with water and household cleaner.
- Have a weather and scratch resistant anti-glare surface.
- Are suitable for use with traditional chalk or Liquid Chalk Pens.
- Can be direct to surface printed.

The specially formulated melamine surface on our premium laminate materials means your chalkboards stay looking new for longer.

 Made To Order

Liquid Chalk Pens

- Pens are rainproof after just 1 hour yet erasable with a damp cloth.
- **Top tip** – Mr Muscle window is an excellent chalkpen cleaner.
- Assorted pack contains: red, green, white, yellow and blue.
- Superior colour vibrancy and outdoor durability shown from our independent outdoor tests.

Nib Size (mm)	Pack Quantity	Colour(s)	Order Code
5 (small)	5	Assorted	CHALKPENSET1
15 (large)	3	White	CHALKPENSET2
15 (large)	5	Assorted	CHALKPENSET3

 In Stock



Wall Chalkboards (Unframed)

Premium high pressure laminate (HPL) chalkboards for indoor or outdoor use.



Pre-drilled in each corner with 5.5mm dia hole.

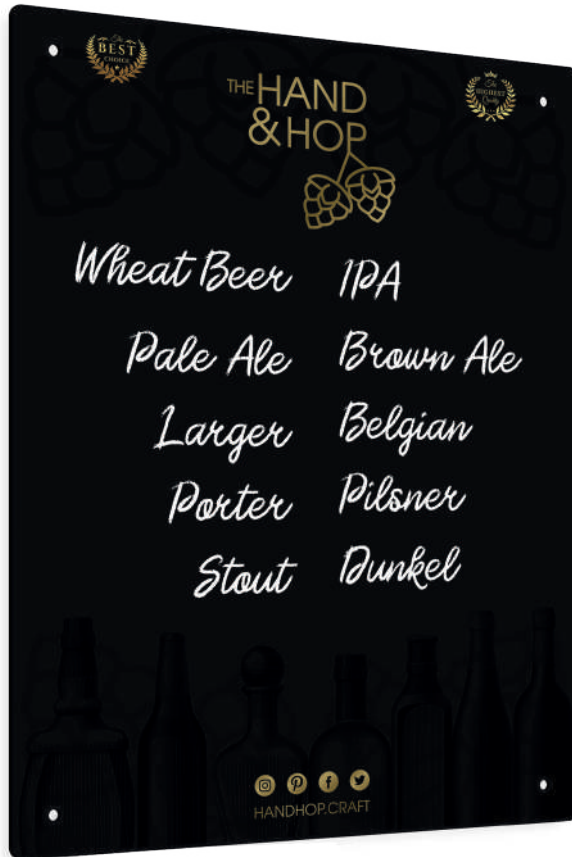

- 3mm thick maintenance-free HPL.
- 5 stock sizes pre-drilled for wall mounting (fixings not included).
- Hard wearing chalkboard surface both sides.
- Solid black material/black edges.
- Easy to clean with a damp cloth (traditional chalk) or household cleaner (Liquid Chalk Pens - see page 93).
- Single or double-sided printing available*.
- Custom sizes/shapes with or without holes available to order*.
- Alternative 2mm and 6mm thicknesses available to order*.
- 'Greenguard' Indoor Air Quality Certified for safe environmental use in schools.

Note – our 6mm melamine faced MDF Easel Chalkboards (see page 103) offer a lower cost option for indoor wall mounting.

* No minimum order quantity.

 In Stock

Display Area (mm)	Dimensions (w x h x d mm)	Weight (kg)	Order Code
206 x 293	210 x 297 x 3	0.3	CWB210X297
294 x 396	298 x 400 x 3	0.5	CWB298X400
396 x 594	400 x 600 x 3	1.1	CWB400X600
594 x 796	600 x 800 x 3	2.2	CWB600X800
796 x 1196	800 x 1200 x 3	4.4	CWB800X1200



Custom sizes/shapes made to order.



Messaging is easy with our Liquid Chalk Pens... (see page 93)



...and easy to remove with commonly available household cleaner.

Chalkboards (Framed)

Reversible certified timber-framed chalkboards manufactured in our Woodworkz® production facility.



- Woodworkz® joinery quality for a long maintenance-free life.
- 4 stock sizes in 'Country Oak' finish.
- For wall mounting, suspending or lean-to floor standing – fixing kit included.
- Hard-wearing panel surface for traditional chalk or liquid chalk pens.
- Exterior grade 6mm thick chalk-face laminated MDF panel in a 45 x 21mm timber frame stained and lacquered for optimum outdoor protection.
- Single or double-sided print available (minimum order quantity 10).
- Custom sizes and colours available (minimum order quantity 20).



Display Area (mm)	O/A Dimensions (w x h x d mm)	Weight (kg)	Order Code
370 x 573	460 x 663 x 21	2.4	CFCO460X663EX
573 x 773	663 x 863 x 21	4.2	CFCO663X863EX
703 x 1073	793 x 1163 x 21	6.4	CFCO793X1163EX



Recyclable: frame, panel and steel fixings

Exterior Leaflet Holders

Round-the-clock promotion, whatever the weather.



Self-closing acrylic lid.

- Made from hard-wearing, crystal clear polystyrene with UV inhibitor for outdoor performance.
- Self closing acrylic lid ensures holder can never be left open and protects literature inside.
- Lid features integrated "please take one" message.
- Ventilation holes on underside minimise condensation.
- Keyhole slots on rear for screw fixing to walls.



Integrated message.

Available in 3 stock sizes



Description	1/3 A4 portrait (DL)	A5 portrait	A4 portrait
O/A Dimensions (mm)	127 x 227 x 40	178 x 227 x 45	248 x 323 x 55
Order Code	EXTLH1/3A4	EXTLHA5	EXTLHA4



Fully Recyclable

Stickers, Labels & Window Graphics

Made to measure stickers and decals that stand out.



- Self-adhesive or self-cling messaging or promotion on any smooth flat surface.
- All sizes and shapes.
- Long-life, indoor/outdoor, permanent/removable, tamper-resistant, clear/frosted.... the options are endless.
- We also offer security/one-way vision window graphics.
- No minimum order quantity.



 Made To Order



Outdoor (Indoor)
Wall/Window Mounted

Stand-Off Sign Fixings

Add an architectural finish to any wall mounted sign panel.

As well as providing an attractive stand-off feature for any sign panel material, these fixings will accommodate an uneven wall surface, which could include any texture or render present on brick or stone wall.

- Allows air to move freely across both the front and rear of the sign panel.
- Eliminates condensation or dirt build-up from behind, essential for clear sign materials, ensuring the message is always visible.
- No apparent screw heads, concealed mounting method acts as an effective tamper deterrent.
- Holds sign panel thicknesses from 2mm to 12mm.
- Supplied in pairs in protective polythene enclosures.
- Screws and wall plugs are not included (since no two surfaces are ever the same, fixings should be selected to suit).
- Use 321 grade Stainless Steel stand-offs for long life outdoors.

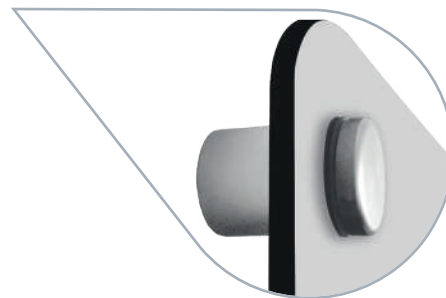

Fully Recyclable

Stand-Off Sign Fixings as used in our Wall Mounted Information Displays.



13mm diameter

Item	O/A Dimensions (Dia x Stand-off height mm)	Panel Thickness Range (mm)	Order Code
Stainless Steel Self Colour	13 x 19	2 – 10	13X19SSSC
Aluminium Satin Silver	13 x 19	2 – 10	13X19ALSS
Aluminium Chrome Plated	13 x 19	2 – 10	13X19ALCP
Brass Plated Gold	13 x 19	2 – 10	13X19BRPG

19mm diameter

Item	O/A Dimensions (Dia x Stand-off height mm)	Panel Thickness Range (mm)	Order Code
Stainless Steel Self Colour	19 x 25	2 – 12	19X25SSSC
Aluminium Satin Silver	19 x 25	2 – 12	19X25ALSS
Aluminium Chrome Plated	19 x 25	2 – 12	19X25ALCP
Brass Plated Gold	19 x 25	2 – 12	19X25BRPG

Stand-Off Sign Fixings Guidance

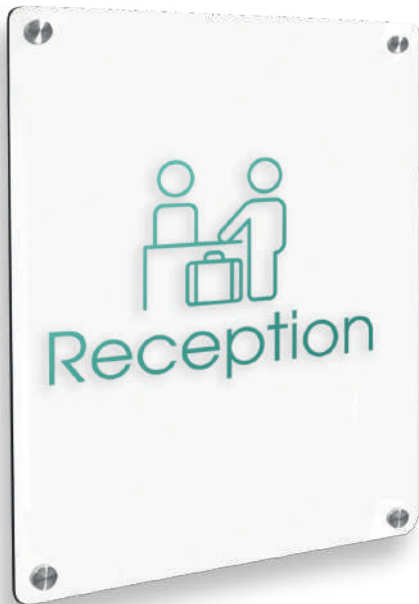
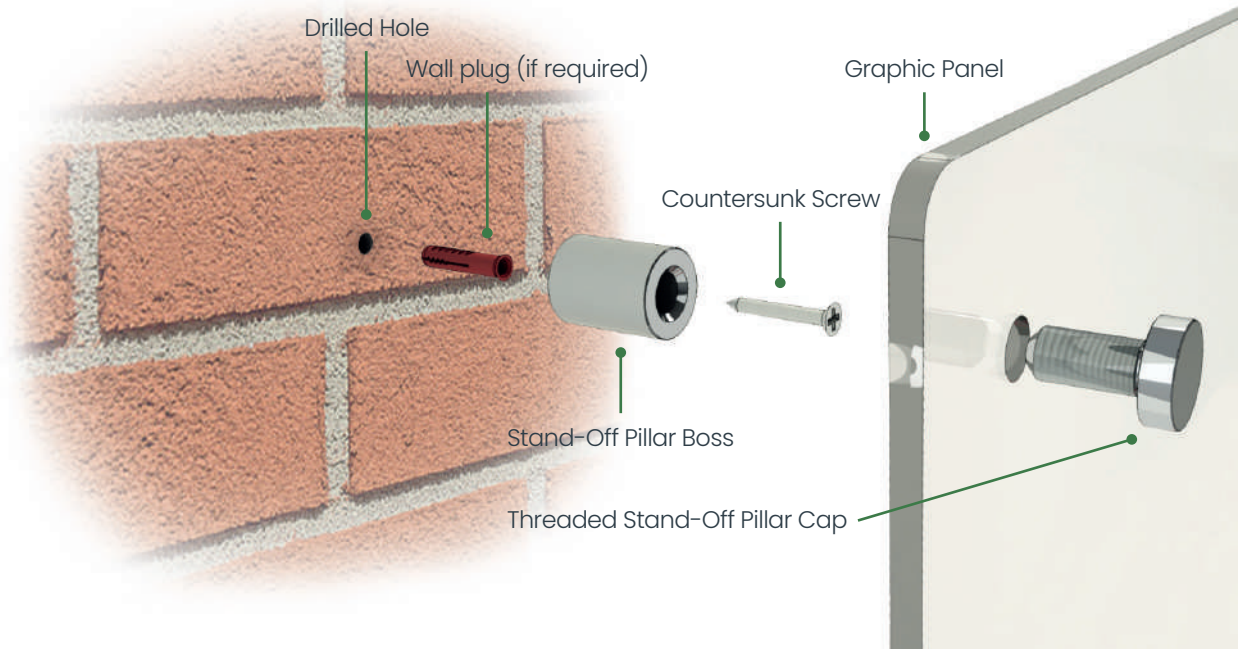

Aluminium
(Chrome Plated)



Brass
(Plated Gold)



Stainless Steel
(321 grade,
brushed)



Aluminium
(Satin Silver)

Screw Selection Guide			
Stand-off Pillar Size	Max. Screw Head Dia.	Max. Screw Thread Dia.	Hole Size in Sign Panel
13mm dia.	6.6mm	No. 6 (3.5mm)	8mm Required
19mm dia.	8.0mm	No. 8 (4.2mm)	10mm Required

BRIDAL EXPO

SUNDAY | MAY
21 | 2022
12:00PM - 4:00PM

FREE
ENTRY



Indoor

Free-Standing/Floor Mounted

Whether you wish to enhance an in-store promotion, or guide or inform customers or visitors, free-standing portable displays which can be repositioned quickly for tactical advantage are essential pieces of marketing equipment.

This section not only includes stands in various styles and sizes for the display of posters, chalkboards and marketing literature but also a range of portable exhibition displays that are as much at home in a retail environment, showroom or reception area as they are at a conference or on a trade exhibition stand. These Roll-Ups, Banner Stands, Back-Drops and Promotional Counters do everything that is asked when it comes to displaying a beautifully printed graphic, all in an easy to transport form with carry case included.

For the floor itself we not only offer our impressive Signtac® self-adhesive floor graphics range (see page 66). For entrances, reception or counter check-outs the repositionable rubber backed promotional Feature Floor Mat is another great way to take advantage of this untapped advertising space whatever the flooring surface.

Easel by Woodworkz®

Woodworkz® is our joinery-quality brand of in-house manufactured real wood sign and display products.



We only use sustainable and certified timber sourced from approved sawmills and distributors.

- Simple, low-cost design offering the widest choice of display options on the market.
- Non-slip rubber feet protects floors and helps keep legs in position.
- Part assembled for packing and very quick to erect - no tools required.
- Stock 'Country Oak' finish. Other colours available to order (minimum order quantity 10).
- Easel Chalkboards available separately. See opposite.
- Also suitable for printed panels (max 13mm thick) or poster frames up to 800 x 1200mm/A0 in portrait or landscape orientation.
- Adjustable panel supports provide five height positions.
- Additional pair of panel supports available separately to display 2x Small Easel Chalkboards/A2 poster frames.

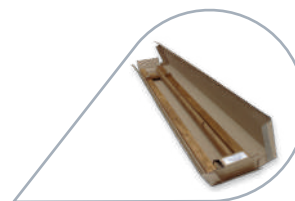

Flat packed and part assembled in individual box.



Fully Recyclable



Easel with alternative poster Snapframe.



Extra supports can be purchased separately.



2x small boards with extra set of supports.



Rear hinge detail.



Easel Chalkboards

- 6mm double-sided black edged melamine faced MDF in 3 stock sizes.
- Slightly rounded corners for safety.
- Suitable for use with traditional chalk or liquid chalk pens (see page 93).
- Direct to surface single or double sided print available (no minimum order quantity).
- Suitable for alternative in-door uses e.g. drilling and screw-fixing to walls.

Product	O/A Dimensions (w x h x d mm)	Weight (kg)	Order Code
Easel	662 x 1549 x 735	2.6	WESLCO
Small Easel Chalkboard	397 x 600 x 6	1.32	WESLB397X600
Medium Easel Chalkboard	600 x 800 x 6	1.8	WESLB600X800
Large Easel Chalkboard	800 x 1200 x 6	4	WESLB800X1200
Additional Supports (pair)	35 dia. x 30 ea.	0.22 (pair)	KNOBCO35PAIR

Pole & Rope Barrier

  Recyclable: stainless steel stanchions, base covers

Choice of our Adfresco® Poles and Bases, with a range of rope styles and colours.



- The LT Pole and Base (shown) offers the lowest cost option and is ideal for internal use.
- Quick and easy to assemble – simple pictorial instructions and spanner included.
- Ropes feature easy clip in attachment – intuitive quick release operation.
- Flat packed for ease of distribution and storage.
- Polished brass finish also available. Minimum order quantity 100. Extended lead times apply.

Please Note: These ropes are designed for a long, maintenance free life indoors. Outdoor use in sunlight or rain will cause the rope colour to fade and reduce the life of the product.

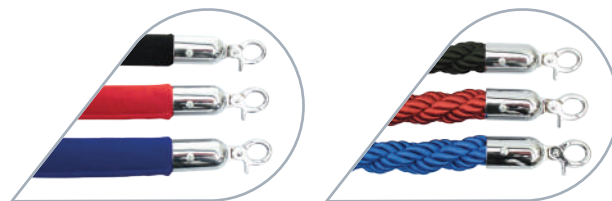

Velvet Rope (left) and Twisted Rope (right)
Available in 3 stock colours.

Item	Colour/Finish	Dimensions (mm)	Weight (kg)	Order Code
Pole and Top Ring	Premium Stainless Steel	Diameter: 113 (Pole Dia. 51mm) Height: 881	1.0	CBBPOLE-SS
	Premium Black		1.5	CBBPOLE-BLK
	Budget LT	Diameter: 100 (Pole Dia. 51mm) Height: 881	1.0	CBBPOLE-201
Base	Premium Stainless Steel	Diameter: 360 Height: 66	13.5	CBBBASE-SS
	Premium Black		13.5	CBBBASE-BLK
	Budget LT	Diameter: 360 Height: 45	10.3	CBBBASE-201
Velvet Rope (with foam core and chrome end clips)	Red	Length: 1500 Diameter: 35	0.6	CBBVROPERED
	Black			CBBVROPEBLACK
	Blue			CBBVROPEBLUE
Twisted Rope (cotton/polyester with weighted core and chrome end clips)	Red	Length: 1500 Diameter: 30	0.6	CBBTROPERED
	Black			CBBTROPEBLACK
	Blue			CBBTROPEBLUE
Eye Plate (for wall mounting)	Chrome	40 x 40 x 35 (w x h x d)	0.06	CBBEYERING



Ropes feature quick and easy clip in attachment.



Chrome plated Eye Plate available for wall mounting

Poster Pillar

Single or double tiered freestanding poster display.



Single Tier

Double Tier

Simple slide-in assembly method:

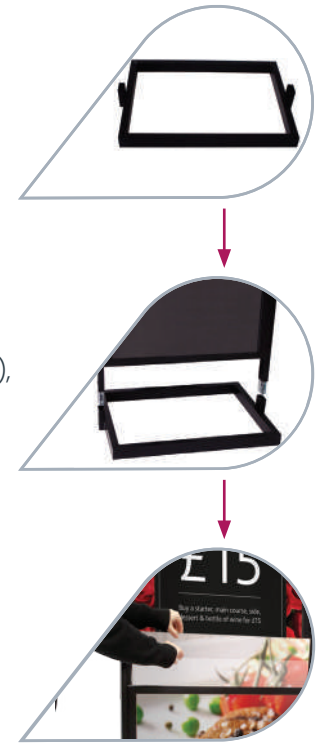

- Simple, functional, low cost double sided design.
- Posters/panels simply slide into place.
- Aluminium frames with a choice of silver anodised or black powder coated finish.
- Black high impact polystyrene (HIPS), inner sheets provide light block between back to back posters.
- Protective anti-glare PET poster cover sheets.
- Allen key and instructions supplied with each flat-pack unit.
- Black Poster Pillars made to order (no minimum order quantity).

Type	Poster/Panel Size (mm)	Display Area (mm)	O/A Dimensions (w x h x d mm)	Weight (kg)	Availability	Finish	Order Code
Small Single Tier	500 x 700	472 x 672	562 x 1595 x 380	7.4	Made to order	Silver	PPST500700SA
	594 x 841 (A1)	566 x 813	656 x 1595 x 380	8	Made to order	Black	PPST500700BLK
Double Tier	500 x 700 (x2)	472 x 672 (x2)	562 x 1595 x 380	8.9	Made to order	Silver	PPDT500700SA
	594 x 841 (x2)	566 x 813 (x2)	656 x 1820 x 450	10	In stock	Black	PPDT500700BLK
					Made to order	Silver	PPDT594841SA
Large Single Tier	500 x 1700	472 x 1672	561 x 1895 x 380	10.9	Made to order	Black	PPDT594841BLK
					In stock	Silver	PPST5001700SA
					Made to order	Black	PPST5001700BLK



Info Board

A1 poster display with optional acrylic brochure shelves.



- Single or double sided A1 poster display.
- Other sizes available made to order (minimum order quantity 10).
- Front opening silver anodised aluminium snapframes for quick and easy poster change.
- Anti-glare PET poster covers.
- Optional single (2 x A4) or double-sided (4 x A4) 4mm clear acrylic brochure shelves.



Single sided brochure shelf.



Double sided brochure shelf.

Poster Size	O/A Dimensions (w x h x d mm)	Type	Pack Weight (kg)	Availability	Order Code
500 x 700mm	660 x 1760 x 450	Single-sided	8.0	Made to order	INFOSG500
		Double-sided	9.5	Made to order	INFODS500
A1	756 x 1760 x 450	Single-sided	8.8	In stock	INFOSGA1
		Double-sided	11.1	In stock	INFODSA1
700 x 1000mm	860 x 1760 x 450	Single-sided	11.0	Made to order	INFOSG700
		Double-sided	13.75	Made to order	INFODS700

Acrylic Brochure Shelves

Shelf Type	Capacity	Dimensions (w x d mm)	Weight (kg)	Order Code
Single sided	2 x A4	440 x 40	1	INFOSHLFSG
Double sided	4 x A4	440 x 40	2	INFOSHLFDS



Recyclable: aluminium frame, PET poster covers, acrylic shelves

Metal Floor Display Stand

Low cost free-standing variable height interior banner display.



- Variable height telescopic display offers flexible double-sided display options.
- Attractive bright chrome finish steel.
- Quick and easy to assemble and change graphics between promotions.
- Adjustable clear spring clips provide secure banner display to suit a variety of graphic widths.
- Small footprint and low profile offers safe and unobtrusive advertising.
- Suitable for paper, card, PVC banner or textile graphic.
- Recommended graphic width is 297mm.
- Height of graphic can vary from 420mm to 1800mm.
- Minimum order quantity 5.
- Print service available. Our standard double sided graphic offer is 440gsm Light Block PVC.



Clear polycarbonate spring clips to suspend graphic.



Telescopic pole clamp for easy height adjustment.



O/A Dimensions (w x h x d mm)	Weight (kg)	Order Code
Min: 495 x 1250 x 251	1.94	FLOORSTAND
Max: 495 x 2100 x 251		



Fully Recyclable



Illuminated Totem

Double-sided freestanding interior poster display.



- Elegant convex design.
- Front opening snapframe sides for quick and easy poster change.
- Silver anodised aluminium casing with silver coated steel base.
- Anti-glare PET poster covers (permanently fixed on one vertical side with magnetic seal on the other).
- Fluorescent tube lighting (single or double depending on size).
- Supplied with 2m cable and plug.
- CE certificate supplied with each unit.



Poster Size (w x h mm)	O/A Dimensions (w x h x d mm)	Weight (kg)	Lighting	Availability	Order Code
600 x 1700	650 x 1720 x 350	28	1 x 58W	Made to order	IT6X17
700 x 1700	750 x 1720 x 350	30.8	1 x 58W	In stock	IT7X17
800 x 1700	850 x 1720 x 370	36.5	2 x 58W	Made to order	IT8X17



Recyclable: aluminium snapframe sides, steel base and top, PET poster covers, acrylic diffuser

Decorative Menuboard

Freestanding internal poster display with front opening snapframe panel.



Landscape

Portrait

- Stylish internal poster display.
- Front opening snapframe for quick and easy poster change.
- Round corners for safety (mitred corners available made to order).
- Anti-glare PET poster cover ensures clarity when under spotlights.
- Polystyrene base with hidden steel plate for added stability.
- Silver anodised aluminium leg (50 x 25mm oval).
- Available in A4 and A3 stock sizes.
- Poster insert – maximum 0.8mm thickness.

2 Displays in 1

Simply undo thumb screw at rear and rotate to landscape or portrait.



Landscape



Portrait

Size	Dimensions (mm)	Display Area (mm)	Weight (kg)	Order Code
A4	O/A height: 1000 Frame: 240 x 327 Base: 250 x 330	279 x 192	3.5	DMBA4LP
A3	O/A height: 1200 Frame: 327 x 450 Base: 300 x 420	402 x 279	6.7	DMBA3LP



Recyclable: aluminium frame and pillar, PET poster cover, polystyrene back panel and mounting, ABS base cover, steel base plate

Portland Menustand

Easy to convert between **portrait** and **landscape**.



Landscape

Portrait

- Telescopic pole for easily adjustable height.
- Simple clip and slide mechanism for height adjustment.
- Front opening snapframes for quick and easy poster change.
- Soft round corners for safety.
- All adjustments made by hand, no tools required.
- Anti-glare PET poster cover sheets ensure clarity of message.
- Base features hidden steel plate for optimum stability.
- Available in A4 and A3 stock sizes.



Easily adjustable height – simply unclip and slide pole up/down.



Quick and easy to change between portrait and landscape format.



Soft round corners for safety.

Size	Format	Dimensions (w x h mm)	Display Area (mm)	Weight (kg)	Order Code
A4	Landscape	330 x 865-1205	190 x 277	5.2	FLEXIMENUBOARDA4
	Portrait	250 x 910-1250			
A3	Landscape	420 x 910-1250	277 x 400	6.8	FLEXIMENUBOARDA3
	Portrait	300 x 970-1310			



Recyclable: aluminim frame and pillar, PET poster cover, ABS base cover, steel pivot-boss and base plate



Instruction Video



Hi-Light Menu Stand

Freestanding LED display for A3 posters.



Portrait

- LED halo effect edgelit illumination for maximum 24/7 visibility.
- Quick and easy to switch between portrait and landscape – 2 in 1!
- Satin black powder coated pole and base with matching poster border.
- Ideal for 'meet and greet', menus, showrooms, galleries and museums.
- 3m power lead supplied.
- Optional 3m extension cable available (see page 201).

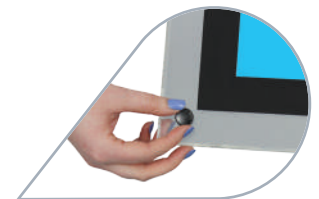
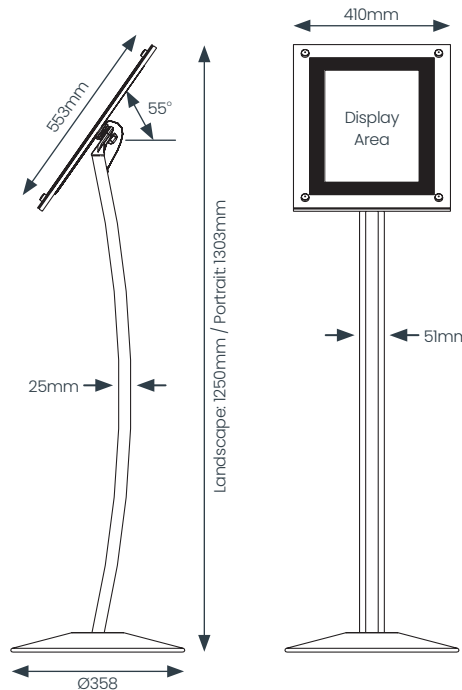

Screws on frame give access to change posters.



Power connector at bottom of pole.



Recyclable: steel base, aluminium pole, acrylic (PMMA) lens panel, polystyrene (PS) mounting

Display Area (mm)	O/A Dimensions (w x h x d mm)	Weight (kg)	Order Code
279 x 402	Portrait: 358 x 1303 x 358	7.2	HILGHTMSA3
	Landscape: 358 x 1250 x 358		

i-Stand

Stylish and minimalist, our new A4 frameless interior poster display stand.



- Frameless A4 landscape format maximises use of poster display area.
- Double-sided design provides walk-round visibility/dual messaging.
- Eye-level poster positioning in a tamper-resistant enclosure.
- Screw clamp holder secures posters and grips insert thicknesses up to 4mm.
- Black slim-line sectional pole offers 3 display height options.
- Solid steel plinth - low centre-of-gravity for high stability.
- Rubber foot pads protect floor surfaces.
- Simple Allen key assembly and poster access (Allen key included).



Frameless poster display.



Screw clamp holder secures poster.



Rubber foot pads to protect floor surface.



Recyclable: aluminium pole and boss, steel base, acrylic poster holder

Display Area (mm)	O/A Dimensions (w x h x d mm)	Weight (kg)	Order Code
A4	330 x 1510 x 330	3	PDSA4B

Basket Showcard Holders

Low cost double-sided indoor poster holder for baskets.



- For attaching A4 or A3 Showcard Frames to wire basket displays, dump bins, etc.
- 2 (tall and short) stock sizes.
- Simple spring loaded design for universal wire mesh application.
- No tools required.
- Minimum order quantity 10.



6 stock colour frame options in 2 sizes.

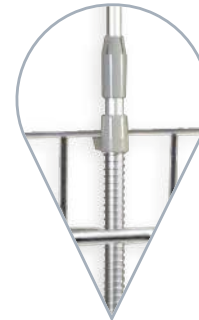

Spring loaded pole simply hooks into place.



Short = 375 - 565mm
Tall = 470 - 765mm



Recyclable: frame, T-clip, aluminium pole, pole mouldings, steel spring

Poster Size	Pole Size	Display Area (mm)	O/A Dimensions (w x h x d mm)	Weight (kg)	Frame Colour	Order Code
A4	Short	194 x 280	Portrait - Min: 215 x 680 x 35 / Max: 215 x 865 x 35 Landscape - Min: 305 x 585 x 35 / Max: 305 x 775 x 35	0.19	Red / Blue / Green / Black / White / Clear	SCSFRAME***A4 + BASKETPOLEA300
A4	Tall	194 x 280	Portrait - Min: 215 x 770 x 35 / Max: 215 x 1070 x 35 Landscape - Min: 305 x 680 x 35 / Max: 305 x 980 x 35	0.22	Red / Blue / Green / Black / White / Clear	SCSFRAME***A4 + BASKETPOLEB400
A3	Short	280 x 404	Portrait - Min: 305 x 800 x 35 / Max: 305 x 990 x 35 Landscape - Min: 428 x 675 x 35 / Max: 428 x 865 x 35	0.26	Red / Blue / Green / Black / White / Clear	SCSFRAME***A3+ BASKETPOLEA300
A3	Tall	280 x 404	Portrait - Min: 305 x 895 x 35 / Max: 305 x 1190 x 35 Landscape - Min: 428 x 765 x 35 / Max: 428 x 1065 x 35	0.28	Red / Blue / Green / Black / White / Clear	SCSFRAME***A3 + BASKETPOLEB400
Optional Anti-glare PVC Poster Sleeve	-	A4: 194 x 280	-	-	-	SCSCOVERA4
		A3: 280 x 404	-	-	-	SCSCOVERA3

*** Replace asterisks with required frame colour eg SCSFRAMEBLACKA4.

Showcard Stands

Low cost double-sided indoor floor stand for quick change promotional offers or as a 'bus stop' information sign.



A3 Tall Portrait



A4 Short Landscape

- Showcard frame in A4 & A3 sizes in 5 stock colours plus clear.
- Portrait or landscape option at assembly.
- Tall and short pole options, each offering telescopic variable height.
- Low-profile off-set grey steel base, suitable for sliding under pallets, dumpbins, case stackers, shelving fixtures, etc.
- Optional anti-glare clear PVC sleeve protector for paper posters.
- Suitable for any lightweight display material up to 2mm thick.
- Minimum order quantity 10.



6 stock colour frame options in 2 sizes.

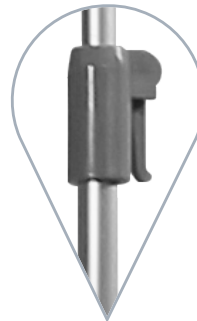

Telescopic pole in 2 sizes.



Simple slide in graphic.



Recyclable: steel base, frame, T-clip, aluminium pole, pole adjustment clips

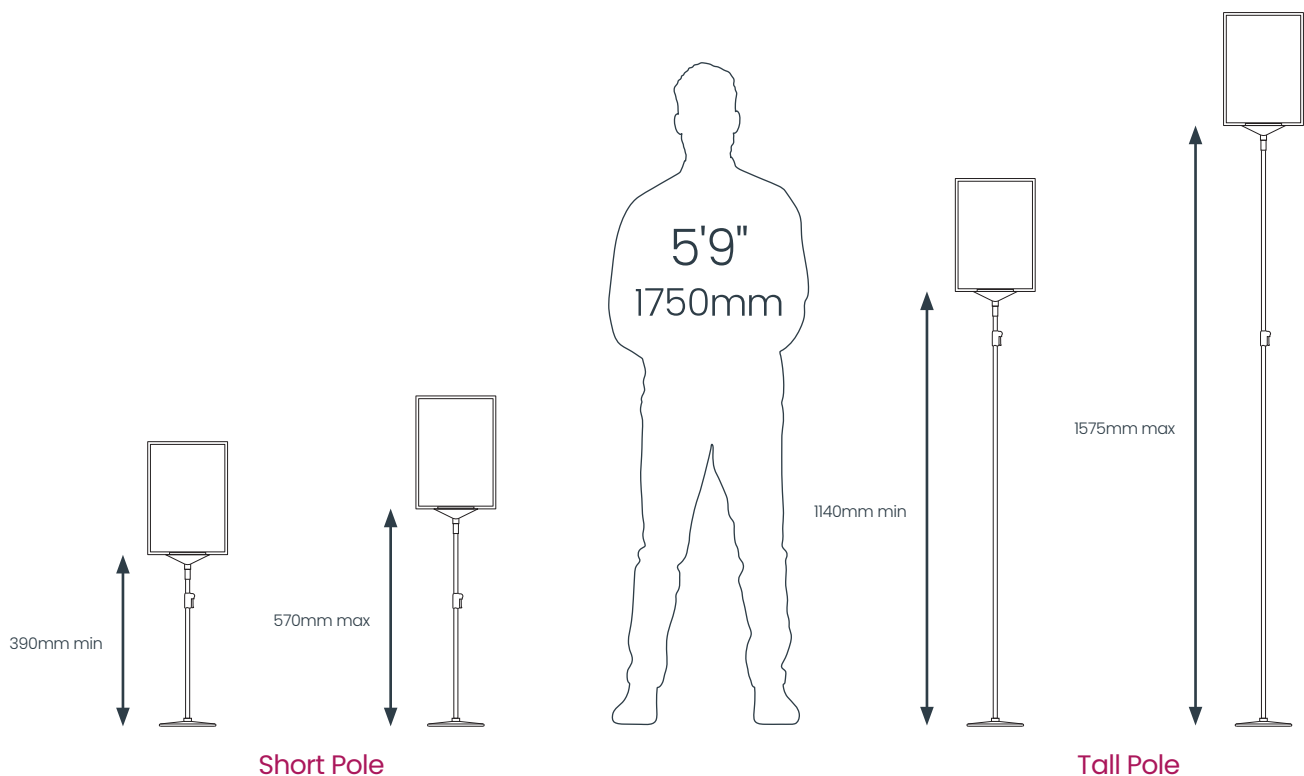

Short Pole

Tall Pole

Poster Size	Pole Size	Display Area (mm)	O/A Dimensions (w x h x d mm)	Weight (kg)	Frame Colour	Order Code
A4	Short	194 x 280	Portrait - Min: 215 x 695 x 210 / Max: 215 x 850 x 210 Landscape - Min: 305 x 605 x 210 / Max: 305 x 800 x 210	0.55	Red / Blue / Green / Black / White / Clear	SCSFRAME***A4 + SCSPOLEA330 + SCSBASE3
A4	Tall	194 x 280	Portrait - Min: 215 x 1450 x 210 / Max: 215 x 1870 x 210 Landscape - Min: 305 x 1355 x 210 / Max: 305 x 1785 x 210	0.62	Red / Blue / Green / Black / White / Clear	SCSFRAME***A4 + SCSPOLEC1050 + SCSBASE3
A3	Short	280 x 404	Portrait - Min: 305 x 820 x 210 / Max: 305 x 1000 x 210 Landscape - Min: 428 x 695 x 210 / Max: 428 x 890 x 210	0.62	Red / Blue / Green / Black / White / Clear	SCSFRAME***A3+ SCSPOLEA330 + SCSBASE3
A3	Tall	280 x 404	Portrait - Min: 305 x 1570 x 210 / Max: 305 x 2000 x 210 Landscape - Min: 428 x 1445 x 210 / Max: 428 x 1870 x 210	0.69	Red / Blue / Green / Black / White / Clear	SCSFRAME***A3 + SCSPOLEC1050 + SCSBASE3
Optional Anti-glare PVC Poster Sleeve	-	A4: 194 x 280	-	-	-	SCSCOVERA4
		A3: 280 x 404				SCSCOVERA3

*** Replace asterisks with required frame colour eg SCSFRAMEBLACKA4.

Flying Banner with Base Plate

High-impact flags on low-profile steel bases for indoor use only.



- Ideal for exhibitions, retail, malls, showrooms, sport and leisure venues.
- Eye-catching 110gsm polyester textile flags on sectional carbon composite poles.
- Flags in 3 shapes and 3 sizes – with printed wrap-around hems.
- Matt black base plate in 2 sizes: Small for all small flags and Large for all medium and large flags.
- Poles simply push-fit onto base spigot.
- For additional product information see Flying Banners on page 48.



Item	O/A Dimensions (w x h x d mm)	Weight (kg)	Order Code
Small Base Plate	300 x 300 x 9 (plate 6mm thick)	4.2	FBBASEPLATESM
Large Base Plate	400 x 400 x 9 (plate 6mm thick)	7.3	FBBASEPLATELG

Item	Size	O/A Height (mm)	Flag Size (mm)	Order Code (Printed Flag)	Order Code (Pole & Bag)
Feather Flag with wrap-around printed pole sleeve	Small	2493	698 x 2323	FBFSMBAN(SW)	FBFSM
	Medium	3480	750 x 3251	FBFMDBAN(SW)	FBFMD
	Large	4688	850 x 4421	FBFLGBAN(SW)	FBFLG
Teardrop Flag with wrap-around printed pole sleeve	Small	2250	771 x 2060	FBTSMBAN(SW)	FBTSM
	Medium	3340	1048 x 3130	FBTMDBAN(SW)	FBTMD
	Large	4925	1144 x 4122	FBTLGBAN(SW)	FBTLG
Rectangular Flag with wrap-around printed pole sleeve	Small	2115	780 x 1770	FBRSMBAN(SW)	FBRSM
	Medium	2897	780 x 2530	FBRMDBAN(SW)	FBRMD
	Large	4020	780 x 3580	FBRLGBAN(SW)	FBRLG

X-Banner

Low cost, high impact, eyeleted banner display - now in 2 sizes.

Instruction Video



- Simple fold away design - no tools required.
- For 600 x 1600mm or 1200 x 2000mm eyeleted banners. Front-Lit materials are recommended.
- Banners simply hook into place - quick and easy to remove and replace.
- Carbon fibre top poles provide excellent tension and stability, ensuring banners do not sag over time.
- Black canvas carry bag included (extra durable black carry case also available - see page 203).
- Banner printing service available (no minimum order quantity).
- Large X-Banner designed to sit side-by-side to form an impressive, easy to transport and very cost effective graphic backdrop.

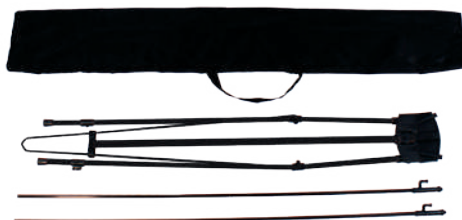

Black canvas carry bag included as standard.



Simply hook eyeleted banner onto frame.



Side view.

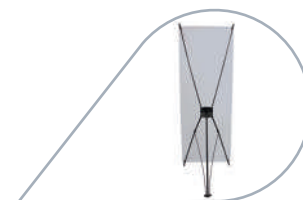

Rear view.

Banner Size (mm)	O/A Dimensions (w x h x d mm)	Weight (kg)	Order Code
600 x 1600	655 x 1690 x 690	2	XBAN600
1200 x 2000	1215 x 2060 x 920	2.7	XBAN1200



Recyclable: aluminium legs, steel leg stay

Quick Banner

Discrete, compact and lightweight banner display.



Single sided front and back view.



Double sided.



Recyclable: aluminium clamp rails, pole and base, steel fasteners, optional PVC banner

- Top and bottom aluminium clamp rails make installing and updating banners quick and easy.
- Double sided units with adjustable pole for final tensioning.
- 2m fixed banner height.
- Buy hardware only or complete with digitally printed 220 micron opaque matt white rigid PVC banner(s), (no minimum order quantity).
- Lightweight carry bag included with each unit.
- Durable black carry cases also available separately (see page 203).

Banner Materials:

- We recommend opaque matt white materials, such as 220 micron PVC or 125-150 micron polyester films for optimum print results and dimensional stability.

Double Sided

Banner Size (mm)	Display Area (mm)	O/A Dimensions (w x h x d mm)	Weight (kg)	Availability	Order Code
600 x 2000	600 x 1970	606 x 2080 x 620	2.3	In Stock	QBD600
700 x 2000	700 x 1970	706 x 2080 x 620	2.7	Made to order	QBD700
800 x 2000	800 x 1970	806 x 2080 x 620	3	In Stock	QBD800
900 x 2000	900 x 1970	906 x 2080 x 620	3.4	Made to order	QBD900
1000 x 2000	1000 x 1970	1006 x 2080 x 620	3.8	In Stock	QBD1000

Single Sided

Banner Size (mm)	Display Area (mm)	O/A Dimensions (w x h x d mm)	Weight (kg)	Availability	Order Code
600 x 2000	600 x 1970	603 x 2060 x 413	1.5	In stock	QBS600
700 x 2000	700 x 1970	703 x 2060 x 413	1.75	Made to order	QBS700
800 x 2000	800 x 1970	803 x 2060 x 413	2	In stock	QBS800
900 x 2000	900 x 1970	903 x 2060 x 413	2.25	Made to order	QBS900
1000 x 2000	1000 x 1970	1003 x 2060 x 413	2.5	In stock	QBS1000



Clamp rails make installing and removing banners quick and easy.



Double sided.

Eco Roll-Up Banner

A more traditional low-cost roll-up option with twin fold-out feet.



- 2 stock sizes – 800mm and 850mm banner widths.
- Non-adjustable fixed height pole.
- Self-adhesive strips at top and bottom for easy banner installation.
- Silver anodised aluminium case, top rail, pole and folding feet.
- Complete with black padded carry case and full instructions.
- Buy hardware only or complete with digitally printed 220 micron opaque matt white rigid PVC banner (no minimum order quantity).

Banner Materials:

- We recommend smooth surface, lightweight rigid roll materials, such as 125 micron grey back polyester or 220 micron matt opaque PVC.
- Flexible, reinforced PVC banner materials have a textured surface and/or incorporate polymers which can react with adhesive tape so should be avoided.
- Do not use materials more than 300 micron thick.



Adhesive top rail bonds to rear top edge of banner.



Top-hat pole/top rail connection.

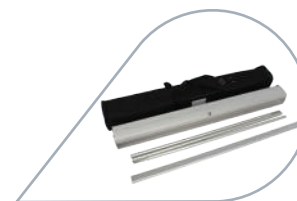

Black padded carry case included with each unit.

Banner Size (mm)	Display Area (mm)	O/A Dimensions (w x h x d mm)	Weight (kg)	Order Code (Single Unit)	Order Code (Pack of 6)
800 x 2100	800 x 1985	820 x 2050 x 365	3	ERB800(1)	ERB800(6)
850 x 2100	850 x 1985	870 x 2050 x 365	3.1	ERB850(1)	ERB850(6)

Please note:

The Eco Roll-Up Banner is designed and built to a market-leading price and the savings derived from the use of lightweight materials and high speed assembly methods to achieve this can result in minor marks or irregularities in the product finish.



Recyclable: aluminium cassette, top rail, folding feet, steel retractor spring

Budget Roll-Up Banner

Instruction Video



The budget roll-up that has it all – style and performance at a super low price.



- 4 stock sizes – 600, 800, 850 and 1000mm banner widths.
- Soft styling – no sharp edges.
- Non-adjustable fixed height pole.
- Top clamp rail and bottom adhesive strip makes banner installation and update a simple process.
- Silver anodised aluminium case and top rail with moulded black fittings and fold-out foot.
- Complete with lightweight black carry case and full instructions.
- Buy hardware only or complete with digitally printed 220 micron opaque matt white rigid PVC banner (no minimum order quantity).
- 6 pack option for an even lower price.

Banner Materials:

- We recommend smooth surface, lightweight rigid roll materials, such as 125 micron grey back polyester or 220 micron matt opaque PVC.
- Do not use materials more than 300 micron thick.

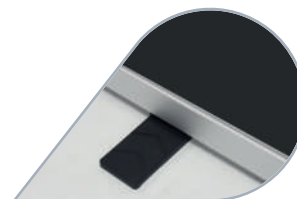

Black centralised folding foot.



Top-hat pole/top rail connection.



Complete with lightweight black carry case.



Black moulded end cap detail and stabilisers.



Recyclable: aluminium cassette, sectional pole, steel retractor spring, moulded end cap and stabilisers

Banner Size (mm)	Display Area (mm)	O/A Dimensions (w x h x d mm)	Weight (kg)	Order Code (Single Unit)	Order Code (Pack of 6)
600 x 2035	600 x 2000	620 x 2090 x 260	1.30	RB600(1)	RB600(6)
800 x 2035	800 x 2000	820 x 2090 x 260	1.84	RB800(1)	RB800(6)
850 x 2035	850 x 2000	870 x 2090 x 260	1.88	RB850(1)	RB850(6)
1000 x 2035	1000 x 2000	1020 x 2090 x 260	2.15	RB1000(1)	RB1000(6)

Budget Banner Connectors

Innovative accessory kit to create a double-sided Budget Roll-Up Banner.

Instruction Video



- Connects two budget banners together easily and securely back to back to create a double sided banner display.
- The specially designed connector grippers slide into the cassette of the banner, then simply twist the handles to secure the connector to the units.
- Secure the two poles of the banner at the top by sliding the connecting joist over the pole caps.



Top connector slides over pole caps.

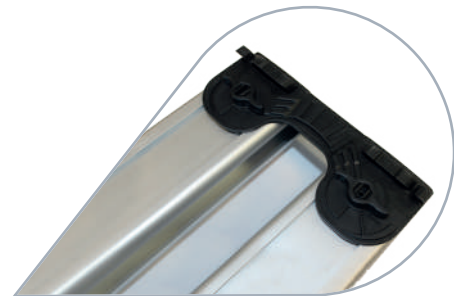

Easily connect two banners together, back to back.



Order Code

RBDS

Rollsby

For all round value, premium roll-ups don't come any better than this.



Premium padded carry case included with each unit, featuring separate pocket for pole and adjustable handle/shoulder strap.



- Single sided premium roll-up for interchangeable banners.
- 2 popular stock sizes – 800 and 850mm banner widths.
- Top clamp rail and bottom velcro strip makes banner installation and update a simple process.
- Two spare self-adhesive velcro strips supplied with each unit for future banner updates.
- Telescopic pole for 1550 – 1990mm height adjustment.
- Stylish silver anodised aluminium casing with black end caps and pole fittings – tough and hard wearing.
- Central stylised chrome foot.
- Premium padded carry case included with adjustable carry strap.
- Buy hardware only or complete with digitally printed 220 micron opaque matt white rigid PVC banner (no minimum order quantity).

Banner Materials:

- We recommend smooth surface, lightweight rigid roll materials, such as 125 micron grey back polyester or 220 micron matt opaque PVC.
- Do not use materials more than 300 micron thick.



Hard wearing/protective end caps.



Stylish chrome foot.



Top clamp rail includes black push-fit end caps.

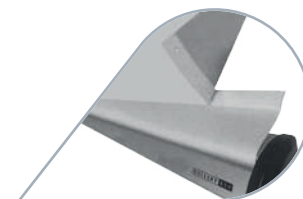

Velcro banner installation.



Recyclable: aluminium canister and pole, steel retractor spring, ABS end caps

Banner Size (w x h mm)	Display Area (w x h mm)	O/A Dimensions (w x h x d mm)	Weight (kg)	Order Code (Single Unit)	Order Code (Pack of 6)
800 x 1760-2200	800 x 1550-1990	860 x 1700-2310 x 400	2.69	ROLL800(1)	ROLL800(6)
850 x 1760-2200	850 x 1550-1990	910 x 1700-2310 x 400	3.4	ROLL850(1)	ROLL850(6)

Promo Stands

Lightweight, portable and cost-effective display counters.

Instruction Video

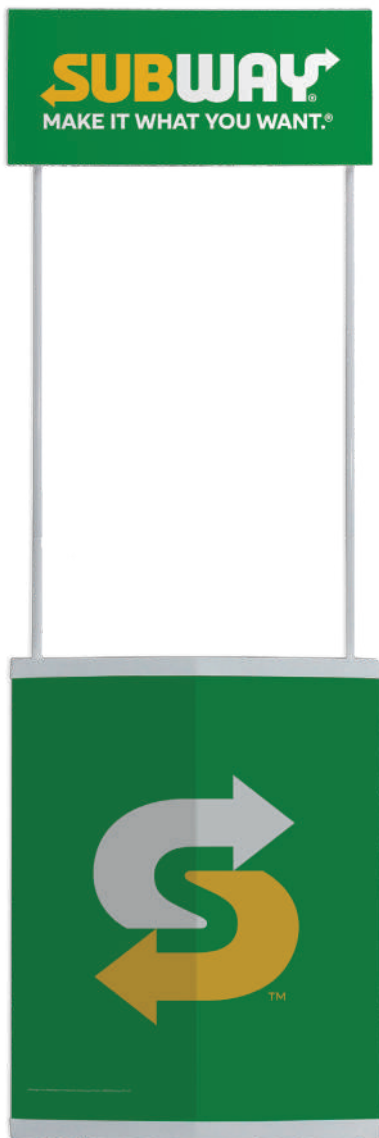

Promo Stand rear view

- Flat-pack design for easy storage and transit.
- Moulded white High Impact Polystyrene (HIPS) counter top, base and shelf.
- White powder coated steel poles.
- White foam PVC header and polypropylene counter panel – ideal for printed vinyl application (no minimum order quantity).
- Supplied complete with carry bag.

Petite Promo Stand:

Panel	Panel Size (mm)	Display Area (mm)	O/A Dimensions (w x h x d mm)	Weight (kg)	Maximum Shelf Weight	Order Code
Header	700 x 300	700 x 300	700 x 2150 x 390	12.8	Counter Top – 20kg Internal Shelf – 10kg	PETITPROMSTDWB
Counter	1596 x 900	1584 x 824*				

* Individual panel display areas – Front: 352 x 824 (x2). Sides: 340 x 824 (x2).

Large Promo Stand:

Panel	Panel Size (mm)	Display Area (mm)	O/A Dimensions (w x h x d mm)	Weight (kg)	Maximum Shelf Weight	Order Code
Header	830 x 350	830 x 350	900 x 2200 x 510	14.1	Counter Top – 25kg Internal Shelf – 15kg	PROMSTDWB
Counter	2004 x 900	1976 x 810*				

* Individual panel display areas – Front: 444 x 810 (x2). Sides: 423 x 810 (x2).



Recyclable: counter top, HIPS shelf & base trays, polypropylene fascia panel, steel poles, foam PVC header

Curved Pop-Up

Great quality. Amazing value for money!

Instruction Video



Each hardware kit includes:

- Collapsible aluminium frame (12mm diameter, silver finish) with black injection moulded fittings - sturdy, durable and long lasting.
- Set of magnetic bars and roll of magnetic B tape.
- Roll of magnetic A tape (for vertical panel edges).
- 2 x 150W clip-on spotlights with cable and plug.
- Semi-rigid trolley/case with built-in wheels and telescopic handle.
- Self adhesive header and kicker strips for panel reinforcement and shaping.
- Panel material is not included if printing your own graphics.

Printed Panels (optional):

- Stand-out digital print on 400 micron opaque white rigid PVC.
- Supplied ready to fit with header/kick-strips pre-applied.
- Option to have laminated in 80 micron matt textured scratch resistant PVC for increased durability and longer life.



Recyclable: aluminium frame sections, steel springs

Size	Dimensions (w x h x d mm)	Option	Total Weight (kg)	Availability	Order Code
3 x 3	O/A: 2610 x 2320 x 660 Panel area: 3440 x 2300 Visual front: 2497 x 2300	Hardware kit	21	In stock	PUC3X3
		+ Printed panels	27	Made to order	PUC3X3PVCDIGSOFT
		+ Lamination	29	Made to order	PUC3X3PVCDIGSOFT-LAM
4 x 3	O/A: 3120 x 2320 x 945 Panel area: 4140 x 2300 Visual front: 3196 x 2300	Hardware kit	26	In stock	PUC3X4
		+ Printed panels	33	Made to order	PUC3X4PVCDIGSOFT
		+ Lamination	36	Made to order	PUC3X4PVCDIGSOFT-LAM

Hard Trolley Case/Counter

For Curved Pop-Ups.

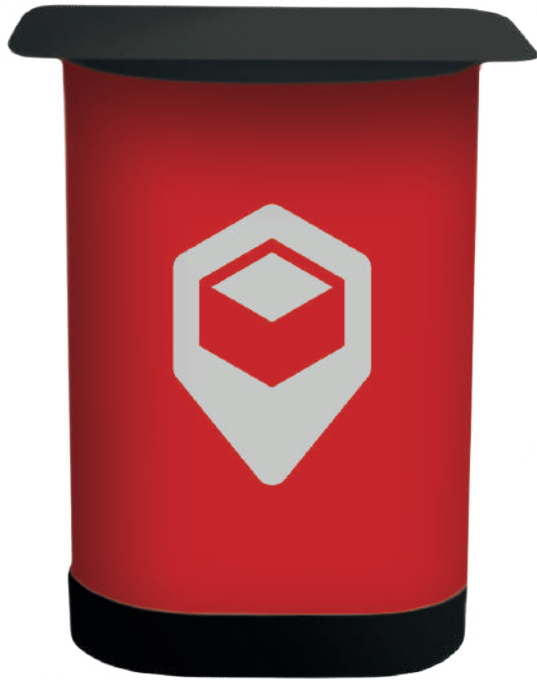

- Sturdy yet lightweight moulded polyethylene case.
- Black hard wearing ABS (hard plastic) counter top – simply unfolds and clips into place. (available separately).
- Built-in wheels for ease of movement.
- Stores all Curved Pop-Up components with space for optional graphic wrap.
- Optional graphic wrap kit includes magnetic fitting strips for quick and easy installation.
- Fitting strips are available for your own graphic wrap production.



Shown with 3 x 3 Curved Pop-Up.

Size	O/A Dimensions (w x h x d mm)	Weight (kg)	Colour	Order Code
Case	593 x 890 x 500	7	Black	MPUC
Counter Top	700 x 500 x 8	2	Black	MPUCTT2
Graphic Wrap	1570 x 755 x 0.46	0.8	White	MPUCGW
Graphic fitting strips only	51 x 755 x 6	0.3	Silver	GWSTRIPS



Recyclable: polyethylene case, PVC graphic wrap, ABS counter top, steel hardware

Promo Counters

Heavier duty flat-pack promotional counters.



- Portable flat-pack design – quick and easy to assemble.
- Choice of two styles with white laminate or wood tops.
- Durable aluminium frames with silver anodised finish.
- White foam PVC display panels.
- Panels suitable for vinyl application or direct to surface print* (no minimum order quantity).
- Optional black carry bags available separately (see page 203).

* Due to possible curvature in convex panels, caution is required when printing direct to surface with flatbed digital printers.

Convex Promo Counter:

O/A Dimensions (w x h x d mm)	Panel Sizes (w x h mm)	Weight (kg)	Top	Availability	Order Code
1060 x 930 x 580	Front: 980 x 878 (x1) Sides: 438 x 878 (x2)	18.1	White	In stock	CONVXW
		20.2	Wood	Made to order	CONVXWOOD

Maximum Loads – counter: 15kg / shelf: 6kg.

Hexagonal Promo Counter:

O/A Dimensions (w x h x d mm)	Panel Sizes (w x h mm)	Weight (kg)	Top	Availability	Order Code
1225 x 930 x 550	Front: 659 x 878 (x1) Sides: 311 x 878 (x4)	19.3	White	Made to order	HEXAGW
		21.3	Wood		HEXAGWOOD

Maximum Loads – counter: 25kg / shelf: 10kg.



Recyclable: aluminium frame,
foam PVC fascia panels

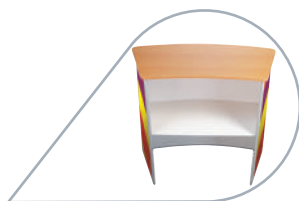

Convex back view with
wood top.



Convex Promo Counter
with white laminate top.



Hexagonal back view
with wood top.



Hexagonal Promo Counter
with white laminate top.

Brochure Display Units

Simple and stylish literature displays.



- Designed to hold between 8 and 32 A4 brochures.
- Silver anodised aluminium frames (50 x 25mm) with acrylic brochure shelves.
- Single and double sided freestanding units available with optional wheels.
- Shelf internal capacity: 40mm (d).



Single/Double Sided	Capacity	O/A Dimensions (w x h x d mm)	Weight (kg)	Availability	Order Code
Single (freestanding)	8 (4 x 2) x A4	546 x 1760 x 450	12.5	Made to order	BRCHSETFREE8
	12 (4 x 3) x A4	766 x 1760 x 450	15.9		BRCHSETFREE12
	16 (4 x 4) x A4	986 x 1760 x 450	19.4		BRCHSETFREE16
Single for wall	8 (4 x 2) x A4	520 x 1450 x 240	13	In stock	BRCHSETWALL8
Double (freestanding)	16 (4 x 2) x A4	546 x 1760 x 450	15.7	Made to order	BRCHSETDSFREE16
	24 (4 x 3) x A4	766 x 1760 x 450	20.2		BRCHSETDSFREE24
	32 (4 x 4) x A4	986 x 1760 x 450	25.7		BRCHSETDSFREE32



Fully Recyclable

Decorative Brochure Stand

Freestanding A4 brochure display plinth.



- A4 brochure display plinth, available in portrait or landscape.
- Clear 3mm polycarbonate display shelf for optimum strength (depth: 100mm).
- Header space provided for graphics if needed.
- Silver anodised aluminium stanchion (50 x 25mm oval).
- Moulded silver plastic base with hidden steel plate for stability.
- Supplied with screws and Allen key for easy assembly.



Display shelf assembly (Allen key supplied).

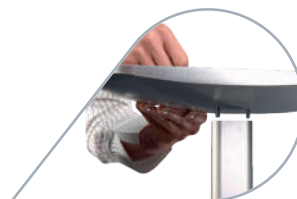

Base/leg assembly (Allen key supplied).



Recyclable: polycarbonate shelf, aluminium pillar, ABS base cover, steel base plate

Poster Size	Format	O/A Dimensions (w x h x d mm)	Weight (kg)	Order Code
A4	Landscape	250 x 970 x 330	3.5	DBSA4L
	Portrait	250 x 1000 x 330		DBSA4P

Spacemaster

Freestanding brochure display with space saving cantilever design.



- Compact and easy to use.
- Supplied complete and ready to use – no assembly required.
- Base fascia suitable for permanent branding (e.g. vinyl graphics).
- Includes 5 x A4 high impact polystyrene brochure holders.
- Supplied complete with black padded carry bag.
- Literature can remain in place when folding down, although we suggest removal of top literature.
- Ideal for presentations, exhibitions, conferences and events.

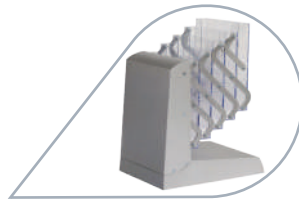

Compact and easy to store.



Hold base firmly and gently pull brochure holders upwards.

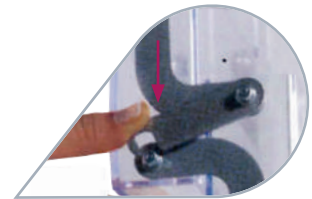

Hook levers to secure the brochure holders in place.



Recyclable: polystyrene brochure holders, steel side plates, ABS moulded fascia and plinth

Base Fascia (w x h mm)	O/A Dimensions (w x h x d mm)	Weight (kg)	Order Code
250 x 280	Erect: 261 x 1345 x 340 Collapsed: 261 x 445 x 340	4.2	SPCEMSTRA4

Brochure Island Stands

Quick and easy to assemble with clip-fit polystyrene brochure holders.

Diamond base with
10 x A4 brochure holders.



2 packs of MULTISHELF5XA4
required.



Hexagonal base with
15 x A4 brochure holders.



3 packs of MULTISHELF5XA4
required.

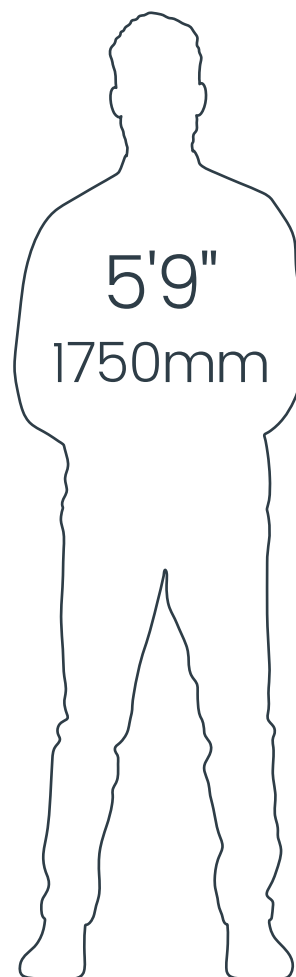

 Recyclable: aluminium frame, polystyrene
brochure holders, polycarbonate clips, steel base plate

- Brochure holder internal depth: 35mm.
- Weighted steel bases for stability.
- Easy to assemble with clip-fit clear polystyrene brochure holders.
- Silver anodised aluminium frame.

Small oval base with
16 x A4 brochure holders.



 Made To Order

Large oval base with
24 x A4 brochure holders.



 Made To Order

Brochure Holders (pack of 5)	Capacity	Order Code
A4	5 x A4	MULTISHELF5XA4



Easy base assembly.



Clip-fit brochure holders.

Brochure Stand	Capacity	O/A Dimensions (w x h x d mm)	Weight (kg)	Order Code
Diamond Base	10 x A4	410 x 1500 x 330	11	MULTISIDEBODY(1)
Hexagonal Base	15 x A4	423 x 1500 x 370	16.2	MULTISIDEBODY(3)
Small Oval Base	16 x A4	600 x 1635 x 350	16.3	OVAL16XA4
Large Oval Base	24 x A4	830 x 1635 x 350	22.4	OVAL24XA4

Modular Pole Display

Low cost free standing display system for posters, brochures & banners.



Holders with side mounting arms.



2-channel pole with Slide-In Frames and Banner set.



2-channel pole with Poster Frames (round corners) and steel Brochure Shelves.

- Ideal for internal/temporary sheltered outdoor use.
- Huge range of display options.



2-channel pole with 2 x 600mm wide Banner Set.



4-channel pole with Slide-In Frames and steel Brochure Shelf.



4-channel pole with Slide-in Frames.



2-channel pole with 4 x steel Brochure Shelves.

Standard Components

For modular pole display.



2-channel pole with circular base and domed end cap.

Pole & Base

- 70 x 70mm silver anodised aluminium poles.
- Silver powder coated steel bases.



Recyclable: aluminium poles, steel bases, polystyrene end caps

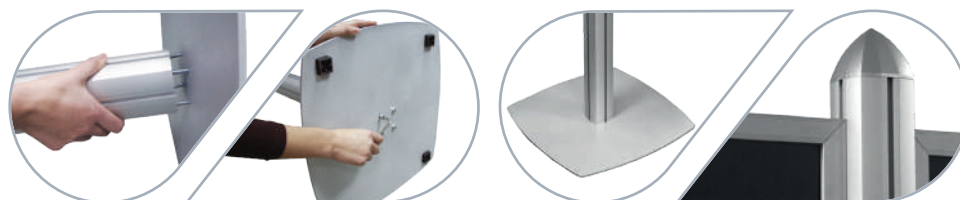

4-channel pole with square base and pyramid end cap.

Pole Type	Base Dimensions (mm)	O/A Height (mm)	Weight (kg) inc. base	Order Code
2-channel	450 (diameter) x 35	1920	12.4	BP2
4-channel	450 x 450 x 35	1920	12.4	BP4



Poster Frames

- Front opening aluminium snapframes for quick and easy poster change.
- 30mm profile, with a choice of round or mitred corners.
- Option to use in portrait or landscape format.
- Supplied with pre-fitted channel slide/clamps.



Fully Recyclable



Slide-in assembly.

Corners	Poster Size	Weight (kg)	Availability	Order Code
Round	A2	1.7	In stock	BPFRAMEA2
Round	500 x 700mm	2	Made to order	PFR500700SA
Round	A1	2.8	In stock	BPFRAMEA1
Round	700 x 1000mm	3.5	Made to order	PFR7001000SA
Mitred	A2	1.7	Made to order	PFA2SA
Mitred	500 x 700mm	2	Made to order	PF500700SA
Mitred	A1	2.8	Made to order	PFAISA
Mitred	700 x 1000mm	3.5	Made to order	PF7001000SA

Standard Components

For modular pole display.



Steel.

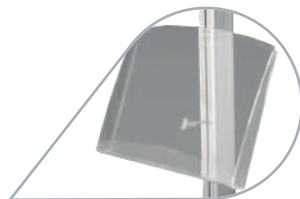

Acrylic.

Brochure Shelves

- 2 x A4 portrait/1 x A3 landscape angled shelves.
- Available in silver powder coated steel or clear acrylic.



Fully Recyclable

Material	O/A Dimensions (w x h x d mm)	Weight (kg)	Availability	Order Code
Steel	460 x 310 x 40	1.8	In stock	BPSTEELSHELF
Acrylic	460 x 310 x 40	1.4	Made to order	BPACRYLICSHelf



2-channel pole and Slide-in Frame assembly.

Slide-in Frames

- Silver anodised aluminium frames with open top end.
- Clear PET poster cover sheets.
- Black polystyrene inner sheet included to provide light block between poster.



Fully Recyclable

Poster Size	O/A Dimensions (w x h x d mm)	Weight (kg)	Order Code
A4 Portrait	233 x 320	0.83	BPSLIFA4
A3 Portrait	320 x 443	1.2	BPSLIFA3
A2 Portrait	443 x 617	1.82	BPSLIFA2



Banner Set (Poster Hangers)

- Supporting arms simply slide into pole and can clamp in place at any height.
- Aluminium Poster Hanger rails top and bottom, suitable for paper or banners up to 1mm thick.
- Concealed banner suspension.
- Printed banners available.



Recyclable: aluminium supporting rails and arms

Banner Height (mm)	Banner Width (mm)	Weight (kg)	Order Code
Up to 1700	400	0.28	BPBANARM400
Up to 1700	500	0.34	BPBANARM500
Up to 1700	600	0.41	BPBANARM600

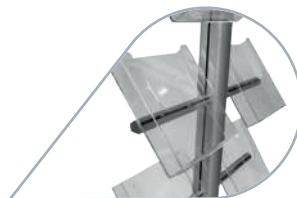
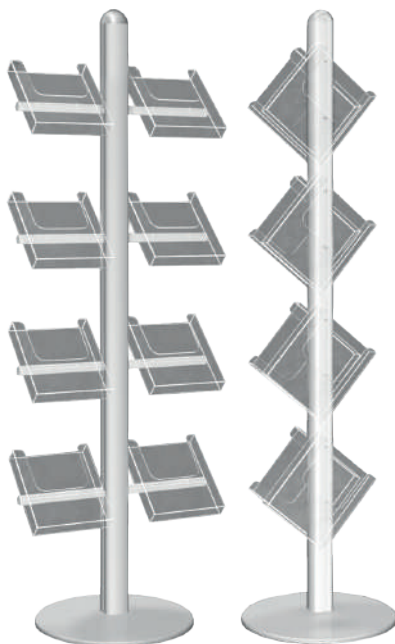

Holders with side mounting arms.

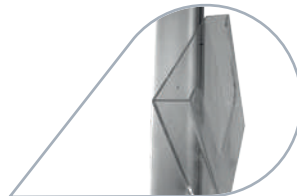

Angled pole mounted holders.

Brochure Holders.

- Made with crystal polystyrene.
- Options for direct pole mounting or side mounting.



Fully Recyclable

Type	Size	Weight (kg)	Availability	Order Code
With side mounting arm	1/3 A4	0.35	Made to order	BPSIDESHELF1/3A4
With side mounting arm	A5	0.55	In stock	BPSIDESHELF5
With side mounting arm	A4	0.85	In stock	BPSIDESHELF4
Angled for pole mounting	A4	0.45	In stock	BPANGBHA4

Free-Standing Tiered Dumpbin

Cost effective impulse sales driver.



- Flat-pack design for low cost distribution.
- Simple no tools assembly.
- Hard wearing crystal polypropylene body on a weighted injection moulded HIPS base.
- Full customisable branding in high definition digital print.
- Optional customisable header for added stand-out.
- Height: 1555/1212mm (with/without header).
- Diameter: 300/400mm (body/base).
- Minimum order quantity 50.

Basket Liners

Increase impulse sales with these quick, easy, low-cost inserts.

- Increase impulse sales amongst basket shoppers.
- Scuff resistant printed promotional inserts.
- Quick, easy and cost-effective.
- Available in square cut or custom shapes.
- No minimum order quantity.

 Made To Order



 Made To Order

Feature Floor Mat

Floor advertising – the great untapped opportunity!



Washable

- The floor is a great place to grab attention in shops, showrooms, receptions and events.
- Stunning print and colour reproduction.
- Feature Floor Mats can be tactically placed by chillers, counters, product displays or entrances.
- 100% polyester on a non-slip rubber backing.
- Hard wearing with safe low-profile edges.
- Simply drop into position – no adhesive required.
- Bespoke sizes available up to 3800mm x 1500mm.
- No minimum order quantity.
- 100% recyclable.



Dimensions include 20mm black low-profile border.

Standard sizes
(mm)

600 x 400

750 x 500

850 x 600

1200 x 850

1500 x 850



Fully Recyclable



Indoor Wall/Window Mounted

Snapframes and the other wall mounted Poster Display, Noticeboard and Menu Case solutions detailed in the outdoor products section of this brochure are perfectly suited for indoor use so make sure you check these out if you don't see what you're looking for.

The same goes for our frameless wall mounted Chalkboards on page 94. Whilst suitable for outdoors their primary use will be indoors, for the hospitality sector and in pubs, bars and cafes in particular. All our Chalkboards have the option to be printed for premium brand endorsement at the point of sale, including the new joinery-quality wood framed boards manufactured in our Woodworkz® production facility.

In this 'indoor only' section you will find some great display solutions for mounting to the inside of a window for outside viewing. Headlinerlite is an excellent repositionable solution for professional poster display, whilst our range of printed Open/Closed Signs offers low-cost brand promotion with built-in functionality for the retailer.

If you are interested in the Illuminated Poster Frames on offer then make sure to check out our stunning Printed Backlit Poster Films, sometimes referred to as Duratrans, on page 194.

Open/Closed Signs

Premium, Slider and Flipper design options, for internal glass mounting.



Premium

- Reverse printed polycarbonate sandwich construction with polypropylene open/closed slider and reversible/updatable opening time/promotional insert.
- Opening time sheets included – peel off and stick in the appropriate day/time slot.
- Adhesive backed for mounting to inside of glass.
- Minimum order quantity: 25



Slider

- 2 piece PVC sign.
- Slide sleeve along to change open/closed message.
- 400 x 105mm.
- High bond adhesive backing included for easy installation.
- No minimum order quantity.



Flipper

- Printed 2 sides on 850 micron high gloss PVC.
- Flip from open on one side to show closed on reverse.
- Custom sizes and shapes available.
- Simple vacuum sucker allows repositioning in seconds.
- No minimum order quantity.



Custom shapes available.

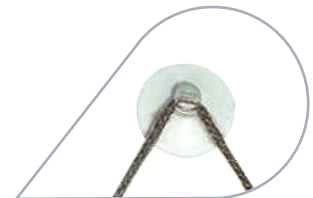

Vacuum sucker.

 Made To Order

Headliner

High visibility fixed poster display for windows.

Instruction Video

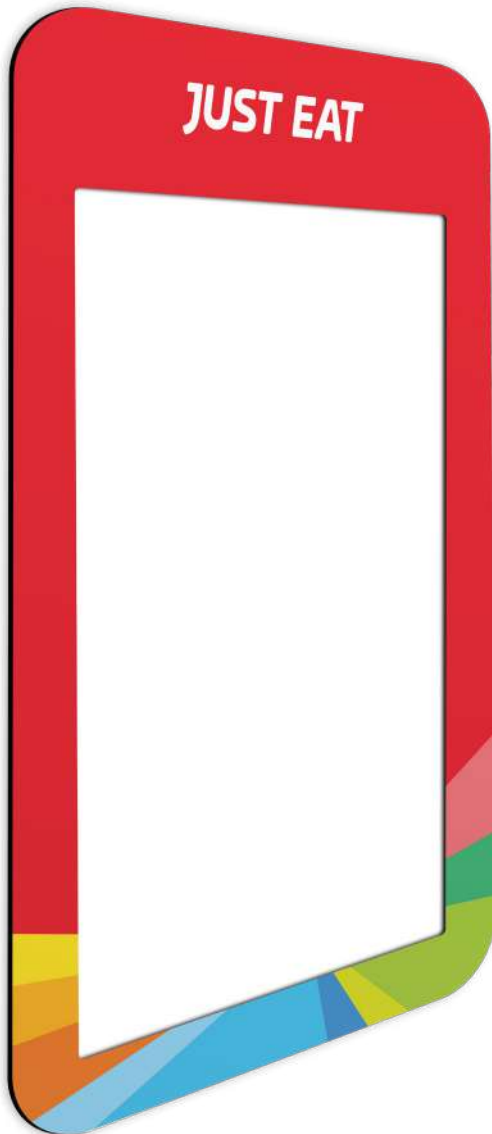

- Single or double-sided poster display.
- Mounted directly to inside of glass with pre-applied clear double sided tape.
- No need for messy Sellotape or Blu Tack.
- Prime positioning for permanent brand presence.
- Hard wearing poster wallet* with magnetic seals ensures poster stays clean, dry and presentable.
- Standard sizes: A4, A3, A2, A1 and 20" x 30".
- Made to order (no minimum order quantity).
- Available with square or rounded corners, with or without headers.
- Custom shapes and sizes available (minimum order quantity 25).



Magnetic seals make it quick and easy to change posters.

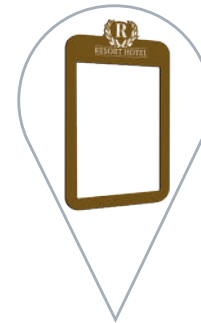

Custom shapes and sizes available.

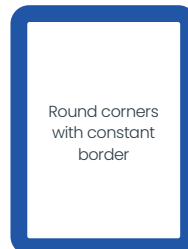

Round corners with constant border

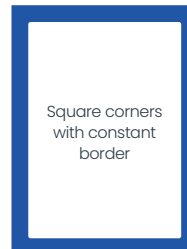

Square corners with constant border

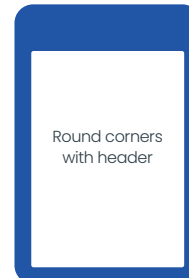

Round corners with header

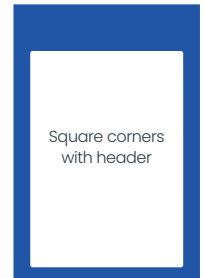

Square corners with header



Recyclable: PVC and polycarbonate

* PVC poster wallet for sizes: A4, A3, A2. Polycarbonate poster wallet for sizes: A1 & 20" x 30".

Headlinerlite

Incredibly simple, cost effective and repositionable window poster display.



- Versatile holder for single or double sided poster display.
- Vacuum suckers and keyhole cut outs make it incredibly quick and easy to install.
- Change posters in seconds - simply lift cover, replace poster and slot cover back in place.
- Consists of two cover sheets (UV stable 700 micron PET) and four vacuum suckers.
- Stock product sold/packed in pairs with window surface cleaning wipes and instructions.
- Available in 4 stock sizes: A4, A3, A2 and A1.

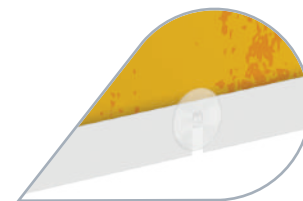

Window suckers for quick and easy installation and poster change.

Available in 4 stock sizes



Recyclable:
PET & PVC suckers

Display Area (mm)	210 x 297	297 x 420	420 x 594	594 x 841
O/A Dimensions (w x h mm)	260 x 347	347 x 470	470 x 644	644 x 891
Weight per unit (kg)	0.2	0.35	0.6	1.15
Availability	Made to order	In Stock	In Stock	In Stock
Order Code (pack of 2)	HEADLINERLITEA4	HEADLINERLITEA3	HEADLINERLITEA2	HEADLINERLITEA1

Minimus

Patent No. 2531204

Minimalist design principles are behind Minimus, the world's simplest and lowest cost snapframe.

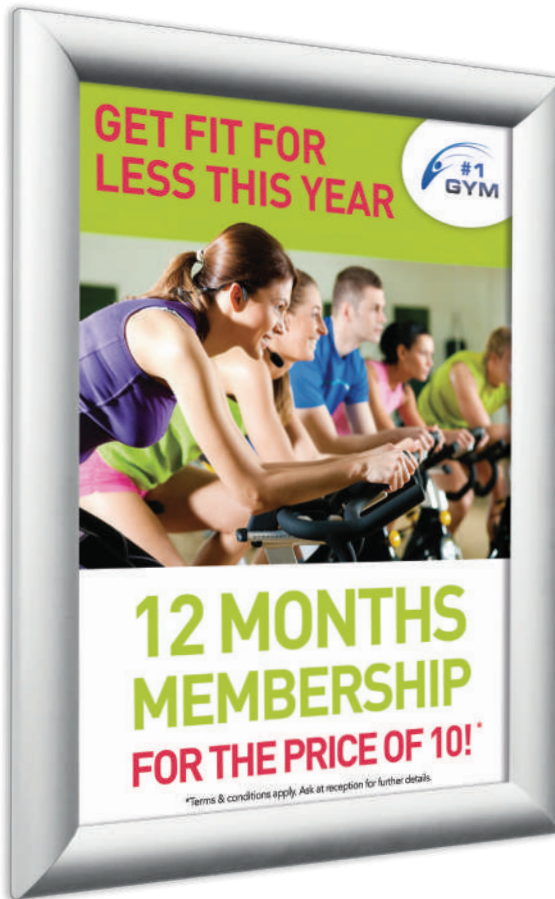

An environmentally conscious snapframe solution!

- Once mounted to a smooth flat surface you wouldn't know Minimus is missing both rear aluminium frame and back panel.
- 25mm profile silver anodised frame in 4 stock sizes: A4, A3, A2 and A1.
- UV stable anti-glare poster cover sheet.
- Supplied with 4 screws/plugs and alternative self-adhesive pads for wall mounting.



Fix in place.

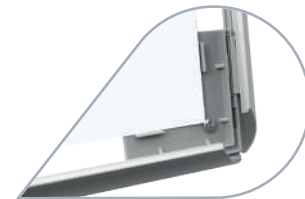

Patented corner mouldings with high tension serrated springs ensure strong grip on the poster.



Insert poster and cover sheet.



Close the sides.



Fully Recyclable

Poster Size	Display Area (mm)	O/A Dimensions (w x h x d mm)	Weight (kg)	Order Code
A4	200 x 285	250 x 335	0.14	MINIMUSA4
A3	283 x 407	334 x 457	0.19	MINIMUSA3
A2	406 x 580	458 x 630	0.33	MINIMUSA2
A1	582 x 828	633 x 880	0.42	MINIMUSA1

Felt Showboard

High quality felt notice boards in a range of sizes and colours.



4x A4 shown.



Recyclable: aluminium frame and back panel, PETG glazing panel, steel fittings



- For internal use in portrait or landscape format.
- Available in 4 sizes with red, blue, green or grey felt backing.
- Suitable for use with Velcro and pins.
- Silver anodised aluminium frames (profile width: 45mm) with PETG glazing panels and galvanised steel back panels.
- Lockable doors for security (1 lock on 4 x A4 size, 2 locks on all other sizes).
- Supplied complete with set of pins, screws, wall plugs and a pair of keys.

Size	Display Area (mm)	O/A Dimensions (w x h x d mm)	Weight (kg)	Availability	Felt Colour	Order Code
4 x A4	483 x 653	585 x 755 x 36	8.5	Made to order	Red	SWF4XA4RD
				In stock	Blue	SWF4XA4BL
				Made to order	Green	SWF4XA4GR
				In stock	Grey	SWF4XA4GY
6 x A4	483 x 973	585 x 1075 x 36	10.4	Made to order	Red	SWF6XA4RD
				In stock	Blue	SWF6XA4BL
				Made to order	Green	SWF6XA4GR
				In stock	Grey	SWF6XA4GY
9 x A4	713 x 973	815 x 1075 x 36	14.1	Made to order	Red	SWF9XA4RD
				In stock	Blue	SWF9XA4BL
				Made to order	Green	SWF9XA4GR
				In stock	Grey	SWF9XA4GY
12 x A4	943 x 973	1045 x 1075 x 36	18	Made to order	Red	SWF12XA4RD
				In stock	Blue	SWF12XA4BL
				Made to order	Green	SWF12XA4GR
				In stock	Grey	SWF12XA4GY



Edgelit XT

Stylish low-profile illuminated poster frame for interior use.



- Specially treated acrylic panel provides strong, even illumination.
- Front opening 25mm profile silver anodised aluminium snapframes for quick and easy poster change.
- 2.5m long power cable with 3-pin plug.
- Anti-glare PET poster covers ensures clarity of message.
- Slim, elegant design: single sided units only 19mm deep.
- Osram LEDs emitting 6500K daylight colour temperature.
- CE certificate supplied with each unit.
- Custom sizes* and colours available made to order (no minimum order quantity).

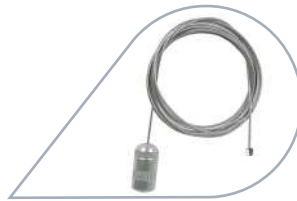

2 x 2m wire cable hanging kit supplied with each double-sided Edgelit XT.



3m extension cable available (page 201).

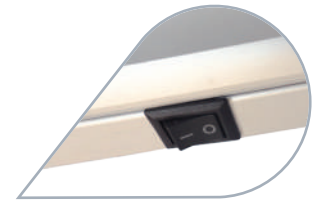

Built-in on/off switch.



Recyclable: aluminium snapframe perimeter frame, PET poster cover, acrylic light panel

Single Sided (for wall mounting):

Poster Size	Display Area (mm)	O/A Dimensions (w x h x d mm)	Weight (kg)	Availability	Order Code
A4	190 x 277	242 x 329 x 19	2.6	Made to order	LEDA4
A3	277 x 400	329 x 452 x 19	3.4	In stock	LEDA3
A2	400 x 574	452 x 626 x 19	4.2	In stock	LEDA2
20" x 30"	488 x 742	540 x 794 x 19	6.7	Made to order	LED23
A1	574 x 821	626 x 873 x 19	8.1	In stock	LEDA1
30" x 40"	742 x 996	794 x 1048 x 19	10.8	In stock	LED34
A0	821 x 1169	873 x 1221 x 19	13.5	In stock	LEDA0

Double Sided (for suspending):

Poster Size	Display Area (mm)	O/A Dimensions (w x h x d mm)	Weight (kg)	Availability	Order Code
A4	190 x 277	242 x 329 x 28	3.1	Made to order	LEDDSA4
A3	277 x 400	329 x 452 x 28	4		LEDDSA3
A2	400 x 574	452 x 626 x 28	5.8		LEDDSA2
20" x 30"	488 x 742	540 x 794 x 28	8.4		LEDDS23
A1	574 x 821	626 x 873 x 28	10		LEDDSA1

*Max size 850 x 1200mm. Max perimeter 4000mm. Max short side 850mm. Max long side 1500mm



Best Buy LEDbox

Economy version of the Edgelit XT.



Similar performance as the Edgelit XT but with the following cost saving differences:

- No built-in on/off switch.
- Lighter frame profiles but external appearance virtually identical.
- 3.5m long power cable with 3-pin plug.
- Double-sided units include hanging points for portrait and landscape (XT must be specified before manufacture).
- CE certificate supplied with each unit.
- Custom sizes* and colours available made to order (no minimum order quantity).

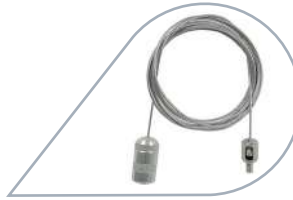

2 x 2m wire cable hanging kit supplied with each double-sided LEDbox.



3m extension cable available (page 201).



Recyclable: aluminium snapframe perimeter frame, PET poster cover, acrylic light panel

Single Sided (for wall mounting):

Poster Size	Display Area (mm)	O/A Dimensions (w x h x d mm)	Weight (kg)	Availability	Order Code
A4	189 x 276	240 x 327 x 18	1.05	In Stock	BBLEDA4
A3	276 x 399	327 x 450 x 18	1.45		BBLEDA3
A2	399 x 573	450 x 624 x 18	2.5		BBLEDA2
20" x 30"	487 x 741	538 x 792 x 18	3.3		BBLED23
A1	573 x 820	624 x 871 x 18	4.5		BBLEDA1
30" x 40"	741 x 995	792 x 1046 x 18	6.35		BBLED34
A0	820 x 1168	871 x 1219 x 18	8.5		BBLEDA0

Double Sided (for suspending):

Poster Size	Display Area (mm)	O/A Dimensions (w x h x d mm)	Weight (kg)	Availability	Order Code
A4	189 x 276	240 x 327 x 30	1.28	Made to order	BBDSLEDA4
A3	276 x 399	327 x 450 x 30	2.09		BBDSLEDA3
A2	399 x 573	450 x 624 x 30	3.67		BBDSLEDA2
20" x 30"	487 x 741	538 x 792 x 30	5.3		BBDSLED23
A1	573 x 820	624 x 871 x 30	7.01		BBDSLEDA1
30" x 40"	741 x 995	792 x 1046 x 30	10.68		BBDSLED34
A0	820 x 1168	871 x 1219 x 30	13.18		BBDSLEDA0

*Max size 850 x 1200mm. Max perimeter 4000mm. Max short side 850mm. Max long side 1500mm



D-Light

Attractive convex lightbox for interior wall mounting.



Option to use in landscape format – ideal for overhead and above-counter displays.

- Keyholes at rear for easy installation, suitable for portrait or landscape displays.
- Aluminium snapframe sides for quick and easy poster change.
- Silver finish steel case (RAL 9006).
- Acrylic opal diffuser panel ensures even light distribution.
- LED illumination gives low power consumption in use.
- 2m power cable, 12V power supply, wall fixings and CE certificate supplied with each unit.
- Custom sizes (no minimum order quantity), max size 850 x 1200mm.
- Custom colours (no minimum order quantity).



Antiglare PET cover sheet protects graphic insert.



Jack-socket and on/off switch.



Recyclable: aluminium snapframe sides, steel case, acrylic diffuser panel, PET poster cover

Poster Size	Display Area (mm)	O/A Dimensions (w x h x d mm)	Weight (kg)	Availability	Order Code
A3	273 x 420	308 x 423 x 82	3	In stock	DLIGHTA3LED
A2	395 x 594	424 x 597 x 98	6	In stock	DLIGHTA2LED
20" x 30"	484 x 762	510 x 765 x 108	7.5	Made to order	DLIGHT23LED
A1	570 x 841	592 x 844 x 120	11.3	In stock	DLIGHTA1LED
30" x 40"	737 x 1016	750 x 1019 x 143	15.5	Made to order	DLIGHT34LED
A0	816 x 1189	828 x 1192 x 150	22	Made to order	DLIGHTA0LED

Sign Nav

Versatile wayfinding display for walls and doors.



Recyclable: aluminium frame, PET poster cover, ABS end caps

- Tamper proof yet easy to open with suction cup provided.
- Suitable for paper, plastic or any flexible material up to 1mm thick.
- Self adhesive strips on reverse for quick and easy installation, no tools or drilling needed.
- Create/update message insert using any desktop printer.
- Anti-reflective covers ensure clarity of message.
- Gives a high quality finish to any message.
- Available in 5 stock sizes, plus a wide range of other sizes available made to order.
- All models suitable for landscape or portrait display.



Self-adhesive strips for no tools installation.

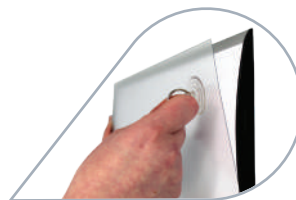

Easily open the display with suction cup provided.



Cover can be pressed into place.

Available in 5 stock sizes



Poster size (mm)	150 x 52	300 x 52	150 x 74	250 x 105	300 x 148
Display Area (mm)	150 x 46	300 x 46	150 x 68	250 x 99	300 x 142
O/A Dimensions (w x h x d mm)	156 x 68 x 14	306 x 68 x 14	156 x 90 x 14	256 x 120 x 14	306 x 162 x 14
Weight (kg)	0.1	0.2	0.1	0.3	0.4
Order Code	SNAV52X15	SNAV52X30	SNAV74X15	SNAV105X25	SNAV148X30

Slatted Magnetic Chalkboard

Remove and re-arrange magnetic slats in seconds.



- Single sided slatted board with option to reverse and use as a stand-alone shaped chalkboard.
- High Pressure Laminate chalkboard panels, suitable for traditional chalk or Liquid Chalk Pens (see page 93).
- 6x 2mm thick slats, each with 500 x 85mm writing area.
- 3mm back panel provides header and footer space for additional message/branding.
- Overall size: 500 x 800mm.
- Made to order plain or printed (no minimum order quantity).



Reverse for single chalkboard display.



Individual magnetic slats.

 Made To Order

Chalkboards (Framed)

Reversible certified timber-framed chalkboards manufactured in our Woodworkz® production facility.



- Woodworkz® joinery quality for a long maintenance-free life.
- 3 stock sizes in 'Country Oak' finish.
- For wall mounting, suspending or lean-to floor standing – fixing kit included.
- Hard-wearing panel surface for traditional chalk or liquid chalk pens.
- 3mm thick chalk-face laminated MDF panel in a 44 x 19.5mm timber frame – stained for indoor use only.
- Perfect for use with our Woodworkz® Easel.
- Single or double-sided print available (no minimum order quantity).
- Custom sizes and colours available (minimum order quantity 20).



Display Area (mm)	O/A Dimensions (w x h x d mm)	Weight (kg)	Order Code
273 x 372	361 x 460 x 19.5	1	CFCO361X460
372 x 575	460 x 663 x 19.5	1.65	CFCO460X663
575 x 775	663 x 863 x 19.5	2.8	CFCO663X863
705 x 1075	793 x 1163 x 19.5	4.1	CFCO793X1163



Recyclable: frame, panel and steel fixings

Wall-Mounted Literature Dispenser

Space efficient display that keeps brochures and literature in easy reach.



White

- Wall mounted display for use in offices, classrooms, shops or showrooms.
- Three transparent A4 pockets provide high visibility for important information, sales literature and hand-outs.
- Secures to any flat wall surface with concealed fixings (included).
- Tough and robust with shatterproof PET-G dividers and recyclable polystyrene body.
- White in stock. Grey and black made to order (no minimum order quantity).



Grey



Black

O/A Dimensions (w x h x d mm)	Weight (kg)	Colour	Availability	Order Code
280 x 600 x 115	1.2	White	In stock	WMLD3XA4W
280 x 600 x 115	1.2	Black	Made to order	WMLD3XA4BLK
280 x 600 x 115	1.2	Grey	Made to order	WMLD3XA4GR



Fully Recyclable

Interior Leaflet Dispensers

Wall mounted crystal clear injection moulded styrene leaflet holders in a wide range of stock sizes.



- Great prices on mass produced lines – 1/3 A4, A5 and A4 single compartment dispensers.
- Colours and branding available on volume orders (minimum order quantities apply).
- Available printed (minimum order quantity 100).
- Other non-stock sizes available to order.
- Additional free-standing models (see page 176).



Fully Recyclable

Single Compartment



1/3 A4 wall mounted



A5 wall mounted



A4 wall mounted

Description	Opening Size (mm)	O/A Dimensions (mm)	Order Code
1/3 A4 wall mounted	110 x 32	114 x 165 x 40	WH110BH
A5 wall mounted	159 x 32	163 x 165 x 40	WH160BH
A4 wall mounted	227 x 32	231 x 249 x 40	WH230BH
4 x A4 portrait stacked freestanding or wall mounted	230 x 32 (x4)	236 x 340 x 175	BH4C230
4 x A4 landscape stacked freestanding or wall mounted	336 x 32 (x4)	340 x 345 x 175	BH4C330

Multi Compartment



4 x A4 portrait stacked
freestanding or wall mounted

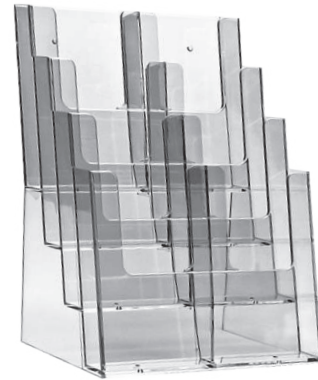

Dividers included for alternative compartment configurations:

4 x A5 landscape, 8 x 1/3A4 (DL) or
mixed display combinations
eg 2 x A4 with 4 x 1/3A4 (DL).



4 x A4 landscape stacked
freestanding or wall mounted



Dividers included for alternative compartment configurations:

8 x A5 portrait, 12 x 1/3A4 (DL) or
mixed display combinations
eg 4 x A5 with 6 x 1/3A4 (DL).

Wall Mounted Information Displays

Fully customisable combination poster and leaflet information boards.



Fully Recyclable

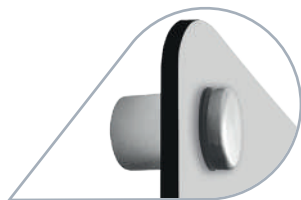

Stainless Steel stand-off fixings.

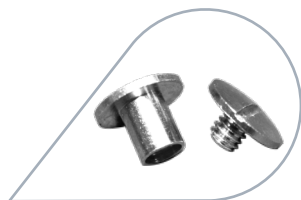

Secure screw fasteners for literature pockets.

Literature Pocket Fixing Guidance

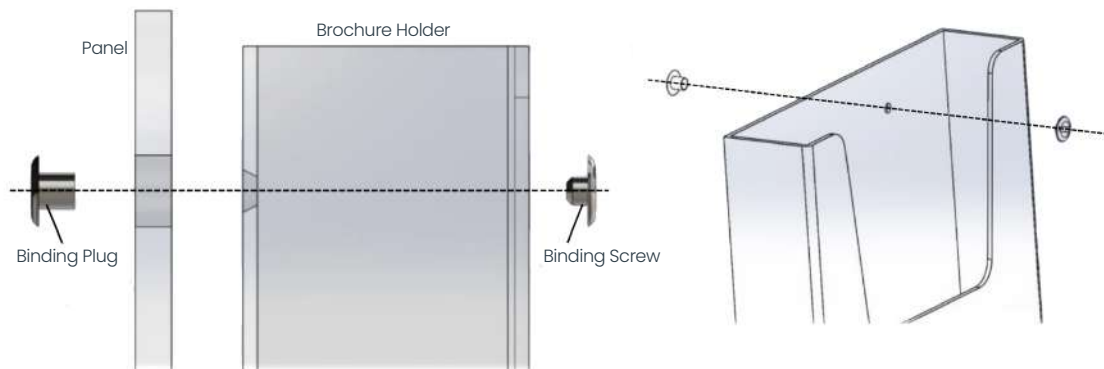

Fastener mounting – literature holders can be replaced individually if required

Our high-quality offer is based on a choice of 3 back panel materials with a set of stainless steel stand-off fixings:

- 5mm Clear Acrylic – plus clear acrylic poster holders and/or clear injection moulded styrene brochure holders.
- 5mm Frosted Acrylic – plus clear acrylic poster holders and/or clear injection moulded styrene brochure holders.
- 3mm Satin White Aluminium Composite (ACM) – plus silver anodised Minimus snapframe poster holders and/or clear injection moulded styrene brochure holders.
- Displays are individually packed with poster frames pre-fitted and brochure holders packed separately for fitting on site (to avoid damage).
- Panels are pre-drilled for both brochure holder attachment and stand-off wall fixings.
- Branding areas to back panels if required.
- Poster holder options – A4, A3, A2 and A1.
- Brochure holder options – 1/3 A4, A5 and A4.
- Made to order (no minimum order quantity).

Individually select elements to create your perfect Wall Mounted Information Display.

Choose your back panel material:



3mm satin white aluminium composite (ACM)

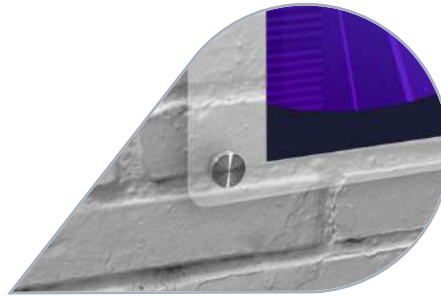

5mm clear acrylic

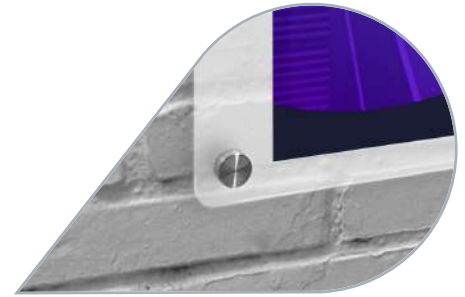

5mm frosted acrylic

Would you like any print on the back panel?

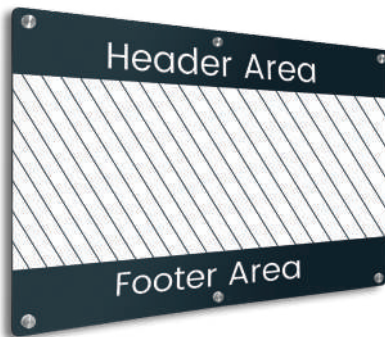

Header and/or footer area.



Print available anywhere on the back panel.

Choose your size and quantity of brochure holders:



A4



A5



1/3 A4

Choose your size and quantity of poster holders:



For Aluminium Composite Material back panels:

A4, A3, A2 or A1 Minimus Snapframes.



For Clear/Frosted Acrylic back panels:

A4, A3, A2 or A1 Acrylic Poster Holders.

Information Display Examples

The following examples are optimised for efficient back panel sheet usage. Please contact us to discuss any other size or configuration, or email a sketch.

Acrylic Back Panel

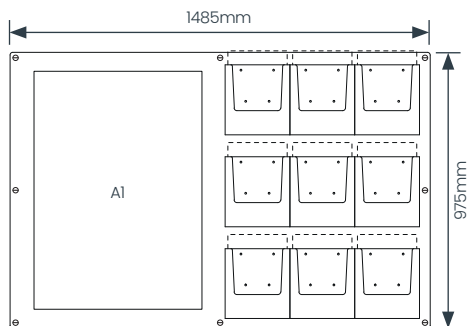

Display element	Quantity included	Order Code
A1 Poster Holder	1	ALGIA1POST9A4BH
A4 Brochure Holders	9	
Header area?	No	

ACM Back Panel

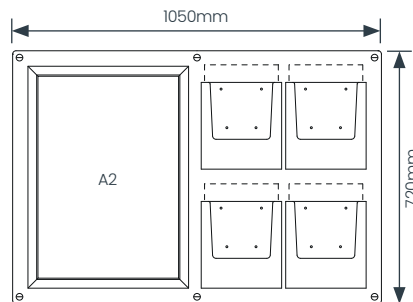

Display element	Quantity included	Order Code
A2 Minimus Snapframe	1	ACMMEIA2MIN4A4BH
A4 Brochure Holders	4	
Header area?	No	

Acrylic Back Panel

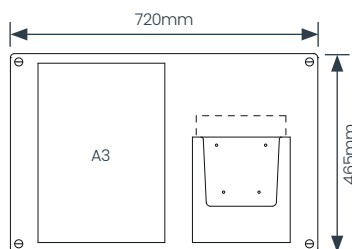

Display element	Quantity included	Order Code
A3 Poster Holder	1	ASMA3POSTIA4BH
A4 Brochure Holder	1	
Header area?	No	

Acrylic Back Panel

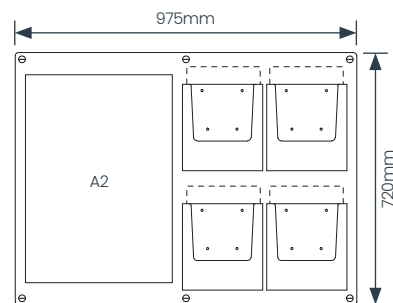

Display element	Quantity included	Order Code
A2 Poster Holder	1	AMEIA2POST4A4BH
A4 Brochure Holders	4	
Header area?	No	

Acrylic Back Panel

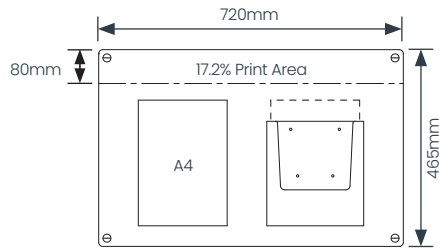

Display element	Quantity included	Order Code
A4 Poster Holder	1	ASMI4POSTIA4BHPH
A4 Brochure Holder	1	
Header area?	Yes	

ACM Back Panel

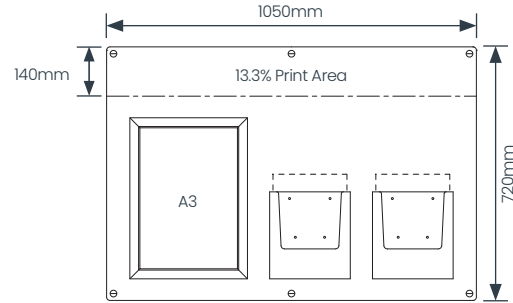

Display element	Quantity included	Order Code
A3 Minimus Snapframe	1	ACMMEIA3MIN2A4BHPH
A4 Brochure Holders	2	
Header area?	Yes	

Acrylic Back Panel

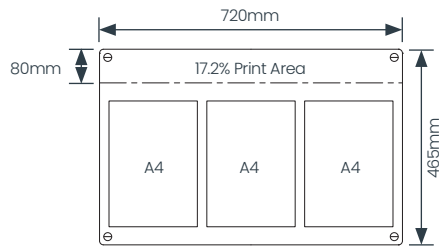

Display element	Quantity included	Order Code
A4 Poster Holders	3	ASM3A4POSTPH
A4 Brochure Holder	0	
Header area?	Yes	

ACM Back Panel

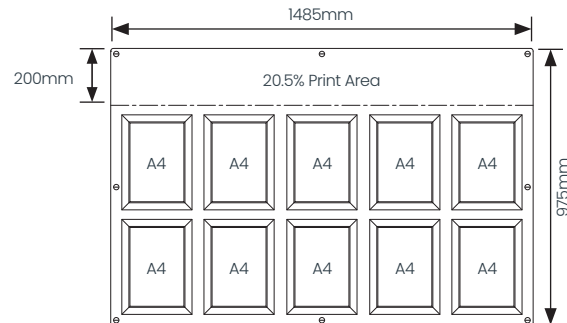

Display element	Quantity included	Order Code
A4 Minimus Snapframe	10	ACMLG10A4MINPH
A4 Brochure Holder	0	
Header area?	Yes	



Indoor Suspended/Hanging

For suspended window and ceiling displays our Poster/Banner Rails are an industry standard solution, and for window dressing in particular Poster Hanger would be our first choice due to its narrow visual profile and matching double-sided appearance.

Our three aluminium Banner Rail products grip the suspended graphic along the top and bottom edge and provide a professional hanging solution for a range of materials and are easy to update. Importantly they keep the graphic straight and hanging true, unlike unsupported card which has a tendency to warp and bend.

Whether floor or wall space is at a premium or not, ceiling suspended advertising makes a lot of sense, in larger stores in particular. Mounted well above head height suspended displays are guaranteed to draw attention to promotions and is where customers will naturally look for navigational guidance around the store.

For smaller stores there are printed Mobiles that offer eye-catching rotation from free movement of air in the store, and if you have lower level suspended ceilings with integrated lighting check out Freelight Plus – probably the lowest cost illuminated display available!

Poster Hanger

Perfect for paper, flexible banner materials and rigid plastics up to 1mm thick.



Adjustable hanging clips with key hole cut-outs for optional wall mounting.

- Plastic grippers make it easy to insert and remove graphics.
- The favourite choice of retailers for window suspended posters.
- Silver anodised finish as standard, also available in any RAL colour (no minimum order quantity).
- Available in custom sizes made to order (minimum order quantity 25).

Each set consists of:

- 2 aluminium rails (slim 20mm wide) with end caps and poster/banner grippers (2-7 per rail depending on size).
- Adjustable hanging clips on top rail.

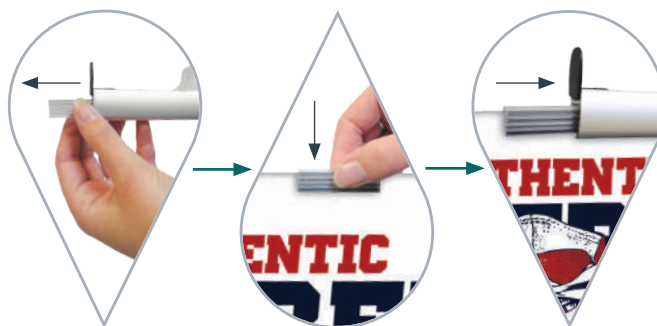

Remove grippers from rail.

Push onto poster.

Insert back into rail.



Recyclable: aluminium rails

Poster/Panel Width (mm)	210 (e.g. A5 or A4)	300 (e.g. A4 or A3)	420 (e.g. A3 or A2)	500	600 (e.g. A2 or A1)	700	850 (e.g. A1 or A0)	1000	1200
Weight (kg)	0.1	0.15	0.2	0.22	0.25	0.3	0.35	0.4	0.5
Availability	Made to order	In stock	In stock	Made to order	In stock	Made to order	In stock	Made to order	In stock
Order Code	PFX210	PFX300	PFX420	PFX500	PFX594	PFX700	PFX841	PFX1000	PFX1200

Poster Snap

Lightweight display solution for paper posters.



- Each set consists of a pair of 26mm aluminium snapframe rails with black end caps and adjustable hanging clips.
- Ideal for wall mounting but can be suspended for window display.
- Silver anodised finish as standard.
- Also available in any RAL colour (no minimum order quantity).
- Available in custom sizes made to order (minimum order quantity 25).



Open snapframe rails.



Position poster and close snapframe rails.

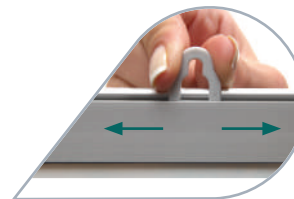

Adjustable hanging clips.



Recyclable: aluminium snapframe rails

Poster Width (mm)	210 (e.g. A5 or A4)	300 (e.g. A4 or A3)	420 (e.g. A3 or A2)	500	600 (e.g. A2 or A1)	700	850 (e.g. A1 or A0)	1000	1200
Weight (kg)	0.15	0.2	0.25	0.3	0.4	0.45	0.5	0.6	0.7
Availability	Made to order	In stock	In stock	In stock	In stock	Made to order	In stock	Made to order	Made to order
Order Code	PS210	PS297	PS420	PS50	PS594	PS700	PS841	PS1000	PS1200

Poster Clamp

Heavy duty gripping action for materials up to 0.5mm thick.



- Ideal for large/heavy weight posters, banners and textiles up to 500 micron thick. For suspending or wall hanging.
- Each set consists of 2x 25mm aluminium rails and 2 adjustable hanging clips.
- Silver anodised finish as standard, also available in any RAL colour (no minimum order quantity).
- Available in custom sizes made to order (minimum order quantity 25).



Open clamping rail and insert poster edge.

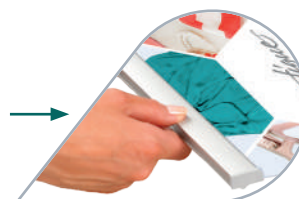

Close clamping rail.

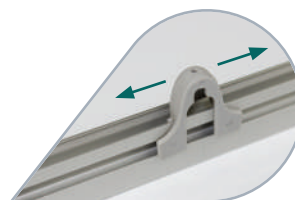

Adjustable hanging clips with key hole cut-out and cable hole.



Recyclable: aluminium rails

Poster/Banner Width (mm)	210 (e.g. A5 or A4)	300 (e.g. A4 or A3)	420 (e.g. A3 or A2)	500	600 (e.g. A2 or A1)	700	850 (e.g. A1 or A0)	1000	1200
Weight (kg)	0.26	0.29	0.4	0.5	0.5	0.65	0.75	0.95	1
Availability	Made to order	Made to order	Made to order	In stock	Made to order	In stock	Made to order	In stock	Made to order
Order Code	PC210(M)	PC297(M)	PC420(M)	PC500(M)	PC594(M)	PC700(M)	PC841(M)	PC1000(M)	PC1200(M)

Cable Suspended Snapframes

Poster display from floor to ceiling.



- Double sided poster display for floor to ceiling/wall mounting.
- Front opening 25mm profile snapframes for quick and easy poster change.
- Includes anti-glare poster cover sheet.
- Silver anodised finish as standard.
- Also available in any RAL colour (made to order, minimum order quantity 25).
- Cable sold per metre to meet individual height requirements.



2 stoppers required per frame.



Stopper grips cable at adjustable height.



Alternative universal ceiling/floor/wall hanger.

Please note: the stock options listed here are only suitable for portrait display and with the same sizes used in series due to cable entry/exit points. Landscape/portrait and different size snapframes for use in the same display are available made to order.



Fully Recyclable

Wire System Components

Item	Stopper for Frames	Ceiling/Floor/Wall Hanger	Cable	Basic Ceiling Hanger
Availability	In stock	In stock	In stock	In stock
Order Code	FASF	FACFH	FAWC	FACH

Double-Sided Snapframes – 25mm Profile with Mitred Corners

Poster Size	Display Area (mm)	O/A Dimensions (w x h x d mm)	Weight (kg)	Availability	Order Code
A4	190 x 275	242 x 325	0.74	In stock	SNDSA425SA
A3	275 x 400	327 x 450	1.0	In stock	SNDSA325SA
A2	400 x 572	450 x 623	1.69	In stock	SNDSA225SA
A1	594 x 841	624 x 871	2.6	Made to order	SNDSA125SA



Freelight Plus

EU Design Registration No. 000433131

Double-sided ceiling mounted display.



- No electricity. No maintenance. Probably the cheapest illuminated display available. Uses existing in-store lighting for illumination.
- Flat-pack design – easy to assemble and install.
- Graphic inserts are quick and easy to update.
- Printed inserts available (no minimum order quantity).

Each kit includes:

- Crystal clear outer lens panel.
- Opal 'lampshade' PVC insert- ideal for translucent vinyl or printed graphics.
- Pair of satin white end caps.
- 2 ceiling hooks and 2 styles of button eyelets.



Recyclable: ABS end caps, polypropylene outer lens panel

O/A Dimensions (w x h x d mm)	Weight (kg)	Order Code
648 x 256 x 226	1.3	FREELIGHTUNB



Coloured and/or pad printed end caps available (minimum order quantity 500).



Existing Lighting

Suspended ceilings offer prime advertising space and, with existing lighting, are perfect for Freelight Plus.



Freelight Plus

With no need for wires or power, Freelight Plus is quick to assemble and simply hooks into place using the fixing kit supplied.



High impact, low cost advertising

Most of the benefits of a traditional lightbox, but without the cost and inconvenience!

Mobiles

Suspended display for reactive or permanent promotions.

3 Connected



- High impact 3 and 4 sided hanging displays.
- Graphic panels simply clip on and off - quick and easy to change.
- Lightweight, flat-packed and easy to assemble.
- Use individually or link together (hooks included).
- No minimum order quantity.

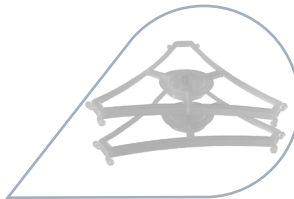

3-sided petite top and bottom mouldings for 240mm - 400mm wide panels.

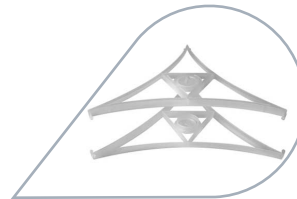

3-sided top and bottom mouldings for 400mm wide panels.

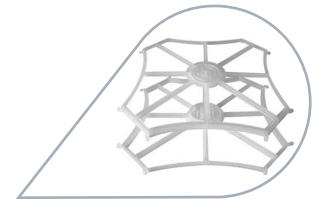

4-sided top and bottom mouldings for 400mm wide panels.



 Made To Order

Magnetic POS Flag Arm

Strong magnetic bracket attaches to any steel surface.



- Sometimes referred to as a Magnetic Aisle Flag Holder or Magnetic Aisle Fin.
- Perfect for double-sided projecting shelf messaging in supermarket and shopping aisles.
- For 210mm wide hanging graphic. Min height 297mm (A4) up to 750mm.
- No mechanical fixings or adhesives – can be easily repositioned if required.
- Preassembled and ready to use straight out of the box.
- 180 degree base rotation allows mounting to horizontal or vertical surfaces.
- Clear polycarbonate sliding hanging hooks to suit variable graphic hole positioning.
- Quick and easy graphic change.
- Suitable for single-sided or double-sided promotional messaging in paper or lightweight card or banner fabrics.
- Minimum order quantity 5.
- Print service available. Our standard double sided graphic offer is 610gsm lightblock PVC.



Magnetic bracket and release button to rotate flag arm.



Mount to horizontal or vertical surfaces.



Ideal for supermarket shelving advertising.



Fully Recyclable

Weight (kg)	Order Code
0.17	MAGFLAGHOLDER

Slatted Chain Chalkboard

The Slatted Chain Chalkboard's unique design allows individual panels to be removed without interfering with the rest of the display.



- Wall-mounted, suspended, single sided, double sided, whole or part reversible, this slatted chalkboard design is brilliant yet simple.
- High Pressure Laminate chalkboard panels, suitable for traditional chalk or Liquid Chalk Pens (see page 93).
- 6x 3mm thick slats, each with 500 x 83mm writing area.
- Fully reversible or choose to reverse individual slats only.
- Overall size: 550 x 935mm (header 210mm deep at centre).
- Header and footer panels ideal for permanent branding.
- Made to order plain or printed (no minimum order quantity).



Holes included for wall mounting if preferred.



Perfect for double-sided hanging or window suspended display.



Individually reversible slats.



Recyclable: steel chains



* BEVERAGES *

Café Latte £4.10
a double shot of espresso with steamed milk and a small layer of foam.

Flat White £4.10
a double shot of espresso with fat steamed milk.

Cappuccino £4.10
a double shot of espresso with equal parts steamed milk and foam.

Mochaccino £4.10
rich chocolate mixed with a double shot of espresso. Served with steamed milk and a small layer of foam.



* DESSERT *

Pecan Pie £4.10
Our classic pecan pie recipe is best served with whipped cream or a scoop of ice cream.

Cheesecake £4.10
Creamy and ultra smooth classic cheesecake with a buttery biscuit base.

Chocolate Cake £4.10
An airy light sponge rich with cream filling and dark chocolate crust. Delicious!

Pretzel Bites £4.10
Perky soft and chewy mini cinnamon sugar pretzel bites - one of the all time tastiest treats!



* BRUNCH *

Crustless Quiche £4.10
Quiche of the day - please see our chalkboard menu for more details.

Buttermilk Tart £4.10
Simple & beautiful - we top ours with fresh cheese, sugar, nutmeg and salted caramel.

Chicken Chivito £4.10
This towering mini sandwich packs a multitude of delicious flavors.

Breakfast Tacos £4.10
Shredded beef, peppers and scrambled eggs makes these breakfast tacos a fun favorite.

..... This is interesting!



65% of the world's coffee is drunk with different additives (milk, cream, spices, alcohol, sugar, salt, cinnamon, lemon)

35% of all coffee in the world is drunk without additives (black coffee without sugar and cream)



1 person in the world per day drinks 3 cups of coffee

Indoor Counter/Table/Shelf

Promotion at the retail shelf display, fixture, service counter, bar or table comes in many forms.

The display products in this section, whether generic or specialist in terms of their market orientation, can be very simple in their form and function, but that doesn't mean we don't give them the same 'design for quality' considerations we apply to all our products.

Lightweight products that are often handled daily and prone to be knocked over or dropped on the floor need to be hard-wearing, durable, hygienic and easy to clean. Minimalist design is as much about optimising the promotion or message as it is about low cost manufacture.

From ticket and menu holders to free-standing leaflet dispensers, poster displays and chalkboards there is a wide choice of solutions for updatable messaging. Counterstand Snapframes, Grip Talker and Grip Chalker and Pivot Gripper are worthy of particular attention.

When it comes to permanently printed solutions for brand endorsement, or to stimulate a call to action at the point of sale, there are low cost Shelf Wobblers to premium acrylic Brand Blocks, innovative flat-pack Dump Bins, Bar Runners and Counter Mats available.

Overture Menu Holder

Crystal clear menu holders for double sided paper inserts.



- Made in injection moulded general purpose polystyrene.
- Designed for style and strength.
- Oval bases with round edges, stylish and easy to clean.
- Finger cut out on top edge, making it quick and easy to change inserts.



Available in 3 stock sizes



A6 Portrait Also suitable for 4" x 6"



A5 Portrait



A4 Portrait



Fully Recyclable

O/A Dimensions (w x h x d mm)	124 x 157 x 65mm	170 x 215 x 70mm	232 x 303 x 90mm
Pack Options	2 / 4 / 25	2 / 4 / 25	2 / 4 / 25
Order Code	OVRTMHA6	OVRTMHA5	OVRTMHA4

Clear Menu Holder

Economical menu protection.



- Smooth, wipe clean PET sleeves and styrene bases.
- Transparent plinth for full visibility.
- Suitable for single or double sided paper inserts.
- Menu sleeve simply push fits in to base.
- Comes in packs of 2 or 10.
- Bases also available printed (minimum order quantity 100).

Available in 3 stock sizes



1/3 A4 (DL)



A5



A4

O/A Dimensions (w x h x d mm)	100 x 220 x 50mm	152 x 238 x 63mm	212 x 330 x 86mm
Pack Options	2 / 10	2 / 10	2 / 10
Order Code	BHV100B + BHV100MH	BHV150B + BHV150MH	BHV210B + BHV210MH



Fully Recyclable

Counterstand Snapframes

Stylish counter top poster frames.



Black

- Front opening aluminium snapframes, for quick and easy poster change.
- Freestanding for versatile/tactical positioning.
- Clip-fit rear stay enables either portrait or landscape presentation.
- Anti-glare PET poster cover sheet ensures clarity of message.
- Includes screws and wall plugs for optional wall mounting.



Silver



Wood



Fully Recyclable



Clip-fit rear stay

Poster Size	Frame Profile (mm)	Display Area (mm)	O/A Dimensions (w x h mm)	Weight (kg)	Availability	Finish	Order Code
A6	14	105 x 148	126 x 169	0.12	Made to order	Silver	OPTIA614SA
						Black	OPTIA614BLK
						Wood	OPTIA614WD
A5	14	138 x 200	170 x 232	0.17	In stock	Silver	OPTIA514SA
						Black	OPTIA514BLK
						Wood	OPTIA514WD
A4	25	190 x 277	240 x 327	0.39	In stock	Silver	OPTIA425SA
						Black	OPTIA425BLK
						Wood	OPTIA425WD

Straight/Tilt Talkers

Crystal clear acrylic menu displays for paper inserts.

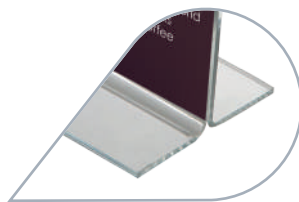
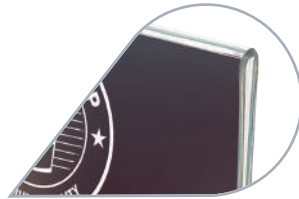

Straight Talkers

- For double sided vertical message display.
- Presents and protects any paper inserts.
- Open edges for poster insert.
- Landscape options made to order (minimum order quantities apply).



Size	O/A Dimensions (w x h x d mm)	Pack Options	Order Code
A6 Portrait	105 x 152 x 75	2 / 4 / 40	STRTA6P
1/3 A4 Portrait	105 x 212 x 75	2 / 4 / 40	STRTI/3A4P
A5 Portrait	150 x 212 x 75	2 / 4 / 30	STRTA5P
A4 Portrait	210 x 302 x 105	2 / 4 / 40	STRTA4P

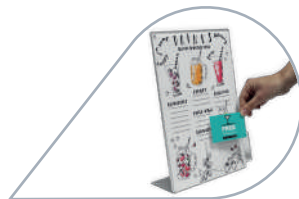

A4 portrait with front leaflet pocket for A7 portrait or business cards.

Tilt Talkers

- For single sided angled message display.
- Presents and protects any paper insert.
- Open edges for poster insert.
- Landscape options made to order (minimum order quantities apply).



Size	O/A Dimensions (w x h x d mm)	Pack Options	Order Code
A6 Portrait	105 x 155 x 72	2 / 5 / 30	TILTA6P
1/3 A4 Portrait	105 x 215 x 72	2 / 5 / 65	TILTI/3A4P
A5 Portrait	150 x 215 x 72	2 / 5 / 40	TILTA5P
A4 Portrait	210 x 305 x 92	2 / 5 / 40	TILTA4P
A4 Portrait with front pocket	210 x 305 x 120	1 / 10	TILTA4PPF

Grip Talkers

Simple yet stylish menu holders featuring our spring powered 'grip-action' bases.



PET Sleeves

- For double sided paper inserts.
- Semi rigid, hardwearing PET, perfect for busy pub and restaurant environments.
- Available in 1/3 A4, A5 and A4 stock sizes.

Bases

- Aluminium with silver anodised finish as standard.
- Spring powered grip action - simply open by hand, insert panel and release.
- Suitable for self adhesive vinyl, polydome stickers or pad printed graphics.
- Available made to order in custom sizes and colours (no minimum order quantity).
- Maximum pad-print height: 14mm. Minimum order quantity 50.

Other Display Options

- These bases are suitable for almost any rigid sheet material between 1-4mm thick. E.g. acrylic, PVC, PET and foam PVC.
- Printed panels available made to order, no minimum order quantity.



Fully Recyclable

Size	Base Dimensions (w x h x d mm)	O/A Height (mm)	Pack Quantity	Weight (kg)	Order Code
1/3 A4 (DL)	100 x 18 x 84	220	2	0.32	SWBASE1/3A4 + BHV100MH
			10	1.1	
A5	148 x 18 x 84	218	2	0.4	SWBASEA5 + BHV150MH
			10	1.6	
A4	210 x 18 x 84	313	2	0.6	SWBASEA4 + BHV210MH
			10	2.6	



Simply grip the base open and insert the sleeve.

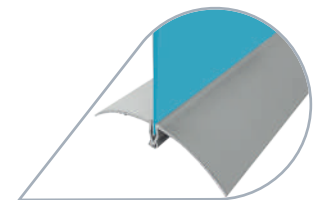

Spring powered grip action bases clamp the insert.

Grip-Action Bases

Spring powered bases – open by hand, insert panel and release.



- Aluminium with silver anodised finish as standard.
- Spring powered grip-action – simply open by hand, insert sleeve and release.
- Holds almost any rigid materials up to 4mm thick.
- Can be branded using self adhesive vinyl, polydome 3D stickers or pad printed graphics.
- Maximum pad print height 14mm (minimum order quantity 50).
- Available in custom sizes, colours and finishes made to order (minimum order quantity 100).
- Take a look at our Grip Chalkers (see page 178) and Grip Talkers (see page 174) for base and panel finished product options.



Fully Recyclable



Simply grip the base open and insert the panel material.

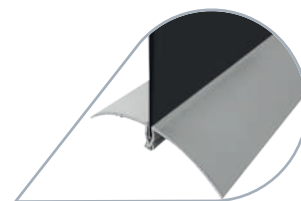

Powerful grip-action.

Size	Base Dimensions (w x h x d mm)	Weight (kg)	Order Code
1/3 A4 (DL)	100 x 18 x 84	0.5	SWBASE1/3A4
A5	148 x 18 x 84	0.8	SWBASEA5
A4	210 x 18 x 84	1	SWBASEA4

Interior Leaflet Dispensers

Free-standing crystal clear injection moulded styrene leaflet holders in a wide range of stock sizes.



- Great prices on mass produced lines – 1/3 A4, A5 and A4 single compartment dispensers.
- Colours and branding available on volume orders (minimum order quantities apply).
- Available printed (minimum order quantity 100).
- Other non-stock sizes available to order.
- Additional wall-mounted models (see page 152).



Fully Recyclable

Single Compartment

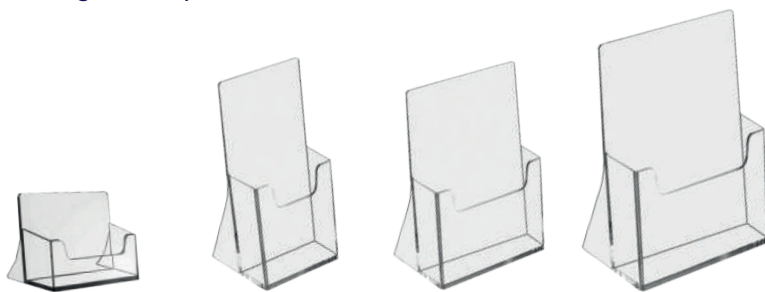

Business Card
freestanding

1/3 A4
freestanding

A5
freestanding

A4
freestanding

Description	Opening Size (mm)	O/A Dimensions (mm)	Order Code
Business Card freestanding	95 x 20	95 x 55 x 39	BUSCRDH
1/3 A4 freestanding	109 x 32	113 x 198 x 83	CT110BH
A5 freestanding	160 x 32	164 x 198 x 83	CT160BH
A4 freestanding	220 x 32	224 x 291 x 96	CT230BH
2 x 1/3 A4 side-by-side freestanding	112 x 32 (x2)	233 x 249 x 85	BH2C112
2 x 1/3 A4 stacked freestanding	110 x 42 (x2)	115 x 270 x 120	BH2C110
4 x 1/3 A4 stacked freestanding	110 x 32 (x2)	115 x 255 x 150	BH4C110
4 x A4 portrait stacked freestanding or wall mounted	230 x 32 (x4)	236 x 340 x 175	BH4C230
4 x A4 landscape stacked freestanding or wall mounted	336 x 32 (x4)	340 x 345 x 175	BH4C330

Multi Compartment



2 x 1/3 A4
side-by-side freestanding



2 x 1/3 A4
stacked freestanding



4 x 1/3 A4
stacked freestanding



4 x A4 portrait stacked
freestanding or wall mounted



Dividers included for alternative compartment configurations:

4 x A5 landscape, 8 x 1/3A4 (DL) or mixed display combinations eg 2 x A4 with 4 x 1/3A4 (DL).

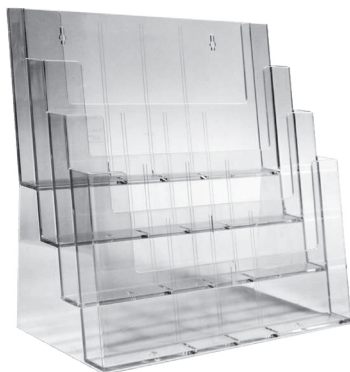

4 x A4 landscape stacked
freestanding or wall mounted

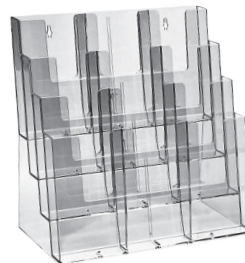

Dividers included for alternative compartment configurations:

8 x A5 portrait, 12 x 1/3A4 (DL) or mixed display combinations eg 4 x A5 with 6 x 1/3A4 (DL).

Grip Chalkers

Table top chalkboards featuring our spring powered Grip-Action Bases.



HPL Chalkboard Panels

- 3mm High Pressure Laminate with round tops as standard.
- Suitable for traditional chalk and Liquid Chalk Pens (see page 93).
- Square top and custom shapes available with optional handle cut-outs (no minimum order quantity).
- Direct to surface print available (no minimum order quantity).

Bases

- Aluminium with silver anodised finish as standard.
- Spring powered grip-action - simply open by hand, insert panel and release.
- Suitable for self-adhesive vinyl, polydome stickers or pad-printed graphics.
- Maximum pad-printed height: 14mm (minimum order quantity 50).
- Custom sizes and colours available to order (no minimum order quantity).
- These bases are suitable for almost any rigid sheet material between 1-4mm thick. E.g. acrylic, PVC, PET and foam PVC.
- Bases can be purchased separately - see page 175.



Recyclable: aluminium base, steel springs

Size	Base Dimensions (w x h x d mm)	O/A Height (mm)	Display Area (mm)	Weight (kg)	Order Code (pack of 2)
A5	148 x 18 x 84	222	148 x 201	2.2	HPLTABLECHALKA5 + SWBASEA5
A4	210 x 18 x 84	309	210 x 288	3.8	HPLTABLECHALKA4 + SWBASEA4



Grip the base open and insert the chalkboard.

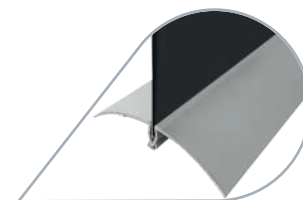

Spring powered grip-action bases.

Counter/Table Top Chalkboards

Traditional, high quality chalkboards with hardwood bases.



- 3mm High Pressure Laminate chalkboard panels, suitable for vinyl application, traditional chalk and Liquid Chalk Pens (see page 93).
- Hardwood (beech) base with a walnut stain.
- Supplied in pairs, fully assembled and ready to use.
- Square top and custom shaped panels available made to order (no minimum order quantity) with optional handle cut outs.
- Direct to surface printed panels available made to order (no minimum order quantity).

Available in 3 stock sizes



Display Area (mm)	148 x 200	210 x 287	297 x 410
O/A Dimensions (w x h x d mm)	148.5 x 221 x 69	210 x 308 x 69	297 x 431 x 69
Weight (kg)	0.27	0.49	0.85
Order Code (pack of 2)	CTCHALKA5	CTCHALKA4	CTCHALKA3

Metal Display Card Holder

Available in 2 finishes and 2 height options.



- Choice of black and polished stainless steel (stainless steel is food hygiene safe).
- Single point spring grip card holder suitable for variable card shapes and sizes.
- Suitable for rigid materials up to 1mm thick.
- Low cost and easy to wipe clean.
- Ideal card display size is 89 x 51mm.
- Minimum order quantity 10.
- Printed cards available.



Also available in black.



Height	O/A Dimensions (w x h mm)	Weight (kg)	Colour	Order Code
100mm	68 x 100 x 80	0.03	Stainless Steel	DHOLDER100SS
		0.04	Black	DHOLDER100BC
200mm	68 x 200 x 80	0.04	Stainless Steel	DHOLDER200SS
		0.05	Black	DHOLDER200BC



Fully Recyclable

Bar Runners

Prime positioning for brands at the point of purchase.



Washable

Standard
Sizes

600 x 190

434 x 234

894 x 244

Dimensions include 12mm
black low-profile border.

- A premium Bar Runner with highly absorbent knitted polyester textile display surface on a lay-flat rubber backing.
- Stunning definition and colour reproduction.
- Easy to clean – wipeable and washable at 30°C.
- Protects counter-tops.
- 100% recyclable
- Minimum order quantity: 10
- Custom size/shapes possible subject to minimum order quantities.



Fully Recyclable

Counter Mat

Capture prime advertising space at the counter or reception desk.



- An adhesive-free 1.5mm gloss white 'soft' PVC promotional counter mat.
- Unique stay-flat, non-slip characteristics with added functionality.
- Sometimes referred to as a Cheque Mat, it offers the perfect surface on which to complete forms or sign documents with a ball-point pen.
- Captures prime advertising space at the counter or reception desk - within retail, hospitality, banks, travel agents, car rental, service outlets, etc.
- Long lasting and easy to clean.
- Custom made in a choice of size and shapes. A popular size is 297 x 200mm.
- No minimum order quantity.



Made To Order

Brand Blocks

Stylish and highly effective brand promotion.

- Establish quality brand presence in store.
- Ideal for windows, counter tops, desks and shelves.
- All blocks are cut to size in high quality crystal clear acrylic.
- Blocks are printed on the reverse face to achieve characteristic visual depth.
- All blocks are diamond edge polished for optimum clarity from every angle.
- Available in block thicknesses of 20, 25, 30mm.
- All sizes and designs are made to order.
- No minimum order quantity.



Fully Recyclable

Dumpbins

Cost effective impulse sales driver.



Freestanding Tiered

- Flat-pack design for low cost distribution.
- Simple no tools assembly.
- Hard wearing crystal clear polypropylene body.
- Fully customisable branding in high definition digital print.

Freestanding Tiered Dumpbin:

- Height: 1555/1212mm (with/without header).
- Diameter 300/400mm (tube/base).
- Optional header for increased stand-out.
- Minimum order quantity 50.

Counter Top Dumpbin:

- Height 250mm, diameter 250mm.
- Minimum order quantity 50.



Counter Top



Fully Recyclable

Wobbler

Simple and effective at getting noticed and prompting impulse purchases.

- Sometimes referred to as a Shelf Wobbler or Display Wobbler.
- Ideal for offer promotions or highlighting product features/benefits.
- Printed on 220 micron gloss white PVC for mounting to a clear 240 micron clear PVC 'wobbler' arm.
- Wobbler arm complete with self-adhesive pad at each end for quick assembly and fixture attachment.
- Graphic size/shape typically within 100 x 123mm overall to suit a 150 x 14mm wobbler arm.
- Other sizes possible. No minimum order quantity.



Fully Recyclable

Ice Cream Holders

Available in a range of sizes.



Acrylic

- Choice of aluminium or clear acrylic.
- Choice of sizes.
- Optional self-adhesive non-slip bumper feet.
- Easy wipe/clean surface.
- Openly display food to encourage impulse purchases.
- No minimum order quantity.



Aluminium



Fully Recyclable

Multi-Cup Display

Ideal for drink brands.

- Effective point of sale display. Informative and visually appealing.
- Precise cut-outs tailored to cup or drinks dispenser. Could suit other products/markets.
- High impact polystyrene - lightweight and easy to clean.
- Minimum order quantity 25.



Fully Recyclable

Pivot Grippers

Showcard mounting – ideal for chillers, product displays, shelving gondolas and counters.



- Simply stick to any smooth surface, insert your promotional material and angle as desired.
- Creates a show card position on any horizontal or vertical mounting surface.
- Clear polycarbonate design ensures nothing spoils the view of your showcard or product information.
- Accepts card and other sheet materials between 0.8 and 2mm thick.
- Strong 3M self adhesive mounting pad sticks reliably to varied smooth surfaces.
- Adjusts 190 degrees through 10 positions for the very best display angle.
- For a complete solution we would be delighted to quote for your printed showcards too!
- Sold in packs of 20.

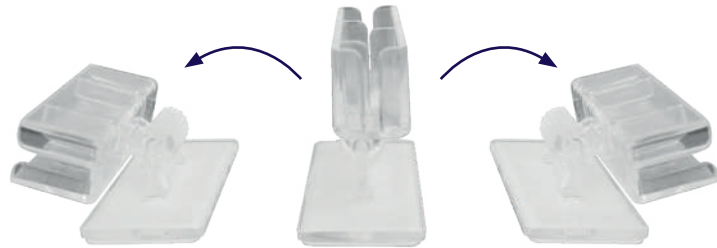

190 degree range of display angles.

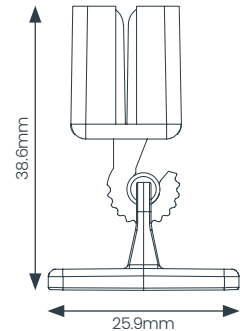
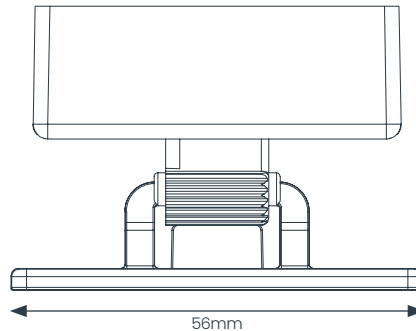

Recyclable:
polycarbonate



Print Services, Printed Posters and Printed Backlit Poster Films

Printed advertising materials are as relevant today, in our world of fragmented digital marketing, as they have ever been. Whether on the printed page or a shop front sign, banner or window sticker, print is reassuring, tangible, credible and engaging, and remains an excellent way to establish and reinforce your brand.

When it comes to applying this to point of sale, events or exhibition graphics, and in particular to longer-life outdoor-durable applications, we are masters at the art.

In addition to the branding that is applied to the majority of the products in this brochure we also offer outdoor durable Printed Posters and have recently introduced high quality Printed Backlit Poster Films, sometimes referred to as a 'Duratrans', for absolutely stunning illuminated promotion indoors and out. There is more information on Printed Posters and Printed Backlit Poster Films at the end of this section.

Our Print Capabilities

From our 67,000 square foot production facility, we offer screen, digital and dye-sublimation print supported by a variety of finishing processes.

Despite the rise of digital print technology, our screen printing department is as busy as ever. These two print processes very much complement one another to offer customers the best of both worlds.

The inks we use across all processes are generally eco-friendly water-based and UV cured, offering a minimum of 2 years of outdoor life. An extended life of 5+ years can be achieved from solvent based screen inks for more permanent signage installations.



Colour Management

As part of our ISO quality management system we operate advanced ColourServer and SmartProfiler colour management to standardise colour profiles and printer calibrations for different output devices. Although fairly common in the off-set/litho print media sector, systems such as this are far less common, but no less important, for large format and digital print.

The benefit to our customers is:

- Consistent colour reproduction across different medias and outputs.
- Improved quality – such as optimised matching of Pantone colours from CMYK/mixed colour digital output.
- The system is also used to calibrate monitors in our artwork department allowing us to produce reliable visual representations of artwork files for proofing and production checks.



Varnish Over-Print

Although varnish is not essential, we sometimes recommend it for signage intended for outdoor use. As digital print is naturally matt, the finish is more inclined to attract dirt which can dull the image.

Benefits of varnish include:

- Enriched colour vibrancy and depth.
- Added protection from dirt and atmospheric pollution.
- Will help to repel dirt and keep the print looking brighter longer.
- Improved scuff and scratch resistance.
- Improved resistance to chemicals and solvents.
- Adds gloss.



Digital Printing

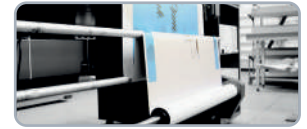

Some of the benefits of digital print:

- Full-colour photographic images
- One-offs/short runs and sampling
- Multiple/variable designs in a run
- High definition close-up viewing
- Printing onto uneven/textured surfaces

Digital printing offers faster turn-around and lower cost than screen on smaller runs because set-up times are minimal. Your digital artwork files once checked are ripped to one of our flat-bed or roll-fed printers which print all colours in a single pass. We control output definition and ink percentage depending on intended use or viewing distance.

Our state of the art flat-bed printers are able to offer a variety of finishes including spot varnish. For further details talk to our sales team.

It is very common for us to print a mixture of digital and screen processes to optimise the result and to produce the perfect reproduction of a customer's artwork. Digital is added for full colour elements and screen to add spot Pantone colours and/or varnish.

Screen Printing

Some of the benefits of screen print:

- Precise Pantone or spot colour matching.
- Simple spot or line colour designs.
- Bold, vibrant colours and text due to thicker ink deposits.
- Extended outdoor life.
- Adding varnish to screen or digital prints to enrich colour, add gloss and increase protection.



Screen is not suited to short runs. Artwork has to be colour separated from which a separate film and screen stencil is produced resulting in what can be prohibitive origination/set-up costs.

We manage artwork files and colour separations in-house and produce our own films and screens which keeps costs to a minimum.

Dye-Sublimation

Textile & fabric printing.

Unlike other printing techniques that layer ink onto a surface, dye-sublimation forces the ink to penetrate into the material by use of heat - a heat fixation process. It is used widely and especially for textiles (soft signage) to produce flags, banners and retail/exhibition graphics.

Benefits of dye sublimation:

- Highly scuff resistant as a result of being fixed into the media.
- Produces graphics on textiles that can be washed and folded without fear of damage.
- On thinner fabrics it produces excellent show-through. Although a mirror image on the reverse it is ideal for the likes of double-sided Flying Banners, producing a colour vibrancy on the rear that can be impossible to distinguish from the front.



Printed Posters

We offer a competitive, fast turnaround printed poster service on quantities from one!



- Premium matt white 185mic/155gsm polypropylene poster film.
- Competitively priced outdoor poster solution.
- Waterproof, tear resistant and highly durable.
- Ideal for indoor and minimum 3 - 6 month outdoor use.
- Exceptional print quality.
- All common poster sizes available.
- No minimum order quantity.

For a small additional cost posters can be preloaded in your sign or poster frame prior to despatch. Please call our sales team for more information.

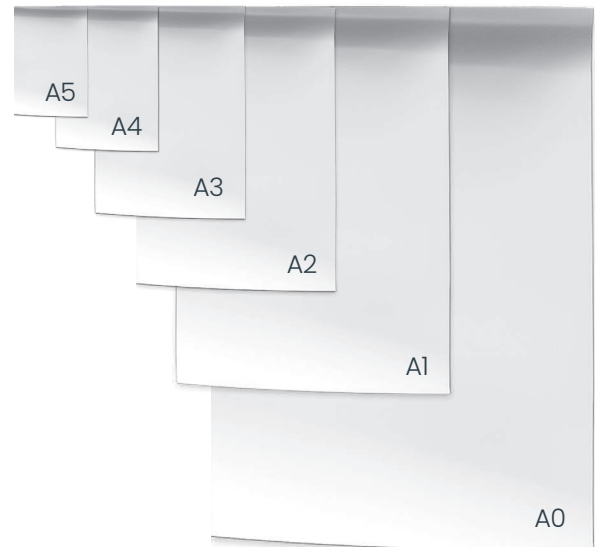

 Made To Order



Printed Backlit Poster Films

Sometimes referred to as a Duratrans or Lightbox Poster these are stunning translucent printed film inserts for 'backlit' lightboxes. The optimised combination of media film, print definition and ink saturation delivers stand-out illuminated graphics of the highest quality.



- Ideal for lobby/reception, menu display, trade outlets, showrooms, shopping malls, airports/duty free, motorway services, casinos, cinemas, restaurants and takeaways, museum and gallery, retail stores, trade show exhibit halls, etc.
- Perfect for lifestyle photos in luxury goods promotion.
- Circa 200 micron polyester film with special diffusion coating.
- Indoor and outdoor film options – both durable, lay-flat and tear resistant.
- Standard and custom sizes up to 1365 x 1800mm (includes 6 sheet).
- Environmentally friendly solvent-free print.
- No minimum order quantity.

Note – Printed Backlit Poster Films will appear darker than normal, only showing their true colours, definition and brilliance once illuminated from behind.



Perfect with our range of edgelit lightboxes.

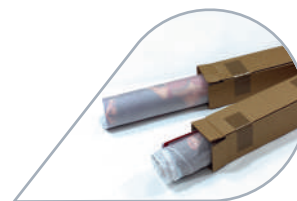

Interleaved, rolled and packed up to 5 to a carton as standard.

 Made To Order



Print Product Overview

Bar Runners

See Page 181



Stickers/Labels/Window Graphics

See Page 97



Feature Floor Mat

See Page 137



PVC Banner

See Page 86



Dealer/Stockist Signs

See Page 70



Open/Closed Signs

See Page 140



Brand Blocks

See Page 182



Counter Mat

See Page 181



Wobbler

See Page 184



Basket Liners

See Page 136



Sign Covers

See Page 37



Bollard Wraps

See Page 47



Signtac Floor Graphics

See Page 66



Accessories & Spares



Image	Product	Colour	Size (mm)	Order Code
	Swinger Aluminium Panels for screen/digital print or vinyl graphics	White	430 x 625 (Eco Swinger)	ECOPANWPAC
			500 x 750 (Swinger 2)	SWI2PWPAC
			588 x 917 (Swinger 3000)	SWI3PWPAC
			674 x 997 (Swinger 4000)	SW4KALIPANPAC
	Swinger Poster Pockets (top-opening) with printed border and magnetic closure (polycarbonate)	White border	281 x 404 (A3, Eco Swinger)	ECOSWPSTPACW
		Black border		ECOSWPSTPACB
		White border	500 x 750 (A2, Swinger 2)	SWING2PSTPACW
		Black border		SWING2PSTPACB
		White border	588 x 917 (20" x 30", Swinger 3000)	SW3KWPSTPAC
		Black border		SW3KBPSTPAC
		White border	674 x 997 (A1, Swinger 4000)	SW4KWPSTPAC
		Black border		SW4KBPSTPAC
	Swinger 3000/4000 Base	Black	688 x 116 x 600	H3BASEBLACK (INC PLUG)
	Panel Hanger for Eco Swinger and Swinger 2 (pack of 2)	Black	21 x 60 x 42	ECOSWDFLEX3REPKIT
	D-Flex Panel Hanger for Swinger 2000, 3000 and 4000 (pack of 2)	Black	15 x 44 x 54	SWIDFLEX2REPKIT
	Tactical Header Clip for Swinger 3000, 4000 and Sentinel*	Black	25 x 52 x 60	SWINGERCLIP01
	Tactical Header Clip for Eco Swinger, Swinger 2, Sightmaster 3 and Spring Sign	Black	46 x 48 x 35	SWINGERCLIP02

Image	Product	Colour	Size (mm)	Order Code
	Eco Swinger Tactical Header	White	480 x 178	THECO
	Swinger 2 Tactical Header		542 x 197	THSWING2
	Swinger 3000 Tactical Header		629 x 231	TH3000
	Swinger 4000 Tactical Header		716 x 230	TH4000
	A1 Sentinel® Tactical Header		625 x 200	THSENA1
	30" x 40" Sentinel® Tactical Header		795 x 215	THSEN34
	A0 Sentinel® Tactical Header		870 x 230	THSENA0
	40" x 60" Sentinel® Tactical Header		1050 x 245	THSEN46
	A1 Sightmaster 3 and Spring Sign Tactical Header		582 x 200	THSM3A1
	30" x 40" Sightmaster 3 Tactical Header		751 x 215	THSM334
	A0 Sightmaster 3 Tactical Header		829 x 230	THSM3A0
	Ecoflexlite Panel (Aluminium) for digital/screen print or vinyl graphics.		White	410 x 795
	Ecoflex 2 Panel (Aluminium) for digital/screen print or vinyl graphics.	White	460 x 850	ECOFLEX2PANPAC
	Ecoflexextra Panel (Aluminium) for digital/screen print or vinyl graphics.	White	540 x 942	ECOFLEXTRAPANPAC

Image	Product	Colour	Size (mm)	Order Code
	Ecoflex 2 HPL Panel for chalk and liquid chalk pens. Can only be used in bases designed for 3mm thick panels	Black	460 x 850 x 3	ECOFLEX2HPLPAC
	Ecoflextra HPL Panel for chalk and liquid chalk pens. Can only be used in bases designed for 3mm thick panels		540 x 942 x 3	ECOFLEXTRAHPLPAC
	Velvet Rope	Red	1.5m (length) x 35mm (dia.)	CBBVROPERED
		Black		CBBVROPEBLACK
		Blue		CBBVROPEBLUE
	Twisted Rope	Red	1.5m (length) x 30mm (dia.)	CBBTROPERED
		Black		CBBTROPEBLACK
		Blue		CBBTROPEBLUE
	Poster Cover Sheets for Snapframes, A-Master, Sightmaster 2 and 3 and Spring Sign (anti-glare 500 micron PET)	Clear	A2 poster	PET420594
			20" x 30" poster	PET508762
			A1 poster	PET594841
			30" x 40" poster	PET7621016
			A0 poster	PET8411189
	Poster Cover Sheets for Defender (anti-glare 500 micron PET)		40" x 60" poster	PET10161524
			30" x 40" poster	PET1028762
	Poster Cover Sheets for Cyclone 2 (gloss clear 700 micron PET)		40" x 60" poster	PET15461036
			40" x 60" poster	PET10161536700M
	Magnetic Poster Cover Sheets for Informer and Booster (anti-glare 500 micron PET with printed border)	White border	A2	INFA2CWPAC
		Black border		INFA2CBPAC
		White border	20" x 30"	INF2030CWPAC
		Black border		INF2030CBLKPAC
		Silver/grey border		INF2030CSPAC
		White border	A1	INFA1CWPAC
		Black border		INFA1CBLKPAC
	Sentinel® Poster Cover Sheets (polycarbonate) with silver printed magnetic border, fixings and Allen key	Clear	30" x 40"	SEN34MK4PANEL
			A0	SENA0MK4PANEL
			40" x 60"	SEN46MK4PANEL

Image	Product	Colour	Size (mm)	Order Code
	Self-Adhesive Magnetic Tape (A)	Brown	12mm x 30m	TAP0006
	Self-Adhesive Magnetic Tape (B)			TAP0043
	Self-Adhesive Steel Tape	White	12mm x 30m	TAP0007
	Budget Banner Connectors (for Budget Roll Up Banner)	Black	-	RBDSC
	Trolley (for various forecourt signs)	Silver	225 x 1220 x 225	TROLLEY
	Adaptor (req'd only for Sightmaster 2)	Silver	90 x 45 x 48	TROLLEYADAPTOR
	Hose (for filling water-fill bases)	Black	3000 x 13	SENHOSE
	Opening Tool for Security Snapframes	Grey	Length: 113	SFS0T01
	Concrete Bases for Defender	Grey	600 diameter for 30" x 40" (53kg)	KIT01
			800 diameter for 40" x 60" (80kg)	KIT02
	Acrylic Brochure Shelves for Info Board	Clear	440 x 40 (single-sided, 2 x A4)	INFOSHLFSG
			440 x 40 (double-sided, 4 x A4)	INFOSHLFDS
	Magnetic Pins for Slimlok Noticeboard, Menu Case and Illuminated Menu Case (set of 8)	White	16 (h) x 12 (diameter)	MAGPINSETS
	LED Power Supply for all single-sided Lightboxes and Menu Cases. Not suitable for use with Illuminated Totem or Lockable Weatherproof Smart LEDbox. (12 volt/6 amp power rating for interior use)	Black	130 x 55 x 32	LEDPS1
	12 volt Extension Cable for Slimlok Illuminated Menu Case, Edgelit XT, D-Light, Hi-light Menu Stand & Best Buy LEDbox	Black	3m	3000MM ADD ON LEAD
	12 volt Extension Cable for Weatherproof Smart LEDbox	Black	2m - Internal Use	2000MMCABLEINT
			2m - External Use	2000MMCABLEEXT
	High Pressure Laminate Chalkboard Panels for Premier A-Boards and Premium Reversible Woodworkz® Chalk A-Board	Black	Small: 563 x 813 x 3	HPLPREMBOARDSTM
			Large: 730 x 1049 x 3	HPLPREMBOARDLG3MM
	5mm Foam PVC Panels for Premier A-Boards	White	Small: 563 x 813 x 5	FOAMPREMBOARDSTM5MM
			Large: 730 x 1049 x 5	FOAMPREMBOARDLG5MM
	3mm Aluminium Composite Material Panels for Premier A-Boards and Premium Reversible Chalk A-Board by Woodworkz®	White	Small: 563 x 813 x 3	ACMPREMBOARDSTM3MM
			Large: 730 x 1049 x 3	ACMPREMBOARDLG3MM











Image	Product	Colour	Size (mm)	Order Code
	Supports for Woodworkz® Easel (pair)	Country Oak	35 (dia.) x 30 (ea.)	KNOBCO35PAIR
	Chalk Insert Panels Turn virtually any poster frame/holder into a chalkboard	Black	A2	INFA2CCB
			20" x 30"	INF2030CCB
			A1	INFA1CCB
	Chalk Pens	Assorted	5 x 5mm nib (small)	CHALKPENSET1
		White	3 x 15mm nib (large)	CHALKPENSET2
		Assorted	5 x 15mm nib (large)	CHALKPENSET3
	Grip-Action Bases for Grip Chalkers and Grip Talkers	Silver	1/3 A4	SWBASE1/3A4
			A5 (148mm)	SWBASEA5
			A4 (210mm)	SWBASEA4
	Cross Base for Flying Banners	Grey	840 x 60	FBBASE(2)
	Water Bag for Flying Banners (use with Cross Base)	Grey	540 diameter	FBBAG(H)
	Ground Spike for Flying Banners	Silver	500	FBSPIKE(2)
	Wheel Base for Flying Banners	Black	480 x 35 x 520	FBWHEEL(2)
	Concrete Base for Flying Banners (with bearing spindle)	Grey	600 (dia.) x 100 (h) (67kg)	FBCONC + FBCONCBRG

Image	Product	Colour	Size (mm)	Order Code
	Tank base with spindle	Black/Chrome	455 x 245 x 255	FBSMTK + TKBRG
	Tank base (second tank) for Flying Banners	Black	455 x 110 x 455	FBSMTK
	Spindle only	Chrome	100 x 132 x 100	TKBRG
	Base Plate for Flying Banners	Black	Small Length: 300 Width: 300 Height: 9 (plate 6mm thick)	FBBASEPLATESM
			Large Length: 400 Width: 400 Height: 9 (plate 6mm thick)	FBBASEPLATELG
	Surface Mount Spindle and Bracket for Flying Banners	Black/Chrome	100 x 132 x 100	FBCONCBRG
	Vertical Wall Mounted Bearing Spindle for Flying Banners	Black/Chrome	100 x 155	FBVERTWALBRG
	Angled Wall Mounted Bearing Spindle for Flying Banners	Black/Chrome	100 x 129	FB25DGWALBRG
	Parasol Base	White	440 x 150 x 440 (20 litre)	PARABASE
	Hard Trolley Case/Counter for Curved Pop-Ups	Black	593 x 890 x 500	MPUC
	Counter top	Black	700 x 500 x 8	MPUCTT2
	Graphic fitting strips only	Silver	51 x 755 x 6	GWSTRIPS
	Graphic Wrap	White	1570 x 755 x 0.46	MPUCGW
	Carry Cases for Quick Banners (BCB10 also for X-Banner Stand)	Black	Banner width: up to 800	BCB8
			Banner width: up to 1000	BCB10
	Carry Bags for Promo Counters	Black	Convex (in stock)	CONVXBG
			Hexagonal (made to order)	HEXAGBG

Outdoor Poster Materials

To ensure best performance against condensation/moisture ingress in outdoor poster advertising, we recommend:

When it comes to outdoors, however good a frame, display or sign holder is at protecting a poster from the weather, the poster media needs to be moisture resistant at the very minimum to help protect it from dampness in the air and worse the soaking that can take place due to condensation.

For short term (up to 3 months) use outdoors, water or moisture resistant paper, sometimes referred to as 'wet strength' paper, should be fine. It is commonly used for pasted billboard advertising.

For longer term use we would recommend synthetic paper, sometimes referred to as 'poly poster', or a plastic film media with appropriate UV and moisture resistant qualities. Laminating paper both sides in a plastic film (encapsulation) is an option but will be expensive in relative terms.

The matt white polypropylene film we use for all our outdoor posters, for short term applications too, offers excellent performance and is competitively priced, even when compared to moisture resistant paper medias.



7 top artwork tips:

- Always make sure that there is ample space around text and images – adhere to safe areas.
- Use High Resolution settings (300dpi) or Vector artwork for maximum quality.
- Utilise complementary colour schemes for inspiration.
- Embed your fonts for accurate reproduction.
- Proof your document thoroughly.
- Convert your graphic to CMYK (leave spot/pantone colours available in your artwork if used).
- Reduce heat absorption (solar gain) on outdoor poster signs by limiting regions of dark colour print.



Paper Sizes



Conversion Table

Size	Millimetres	Inches
A7	74mm x 105mm	2 7/8" x 4 1/8"
1/3 A4	99mm x 210mm	8" x 4 1/4"
A6	105mm x 148mm	4 1/8" x 5 7/8"
A5	148mm x 210mm	5 7/8" x 8 1/4"
A4	210mm x 297mm	8 1/4" x 11 3/4"
A3	297mm x 420mm	11 3/4" x 16 1/2"
A2	420mm x 594mm	16 1/2" x 23 3/8"
20" x 30"	508mm x 762mm	20" x 30"
A1	594mm x 841mm	23 3/8" x 33 1/8"
30" x 40"	762mm x 1016mm	30" x 40"
A0	841mm x 1189mm	33 1/8" x 46 3/4"
40" x 60"	1016mm x 1524mm	40" x 60"

Viewing Distances

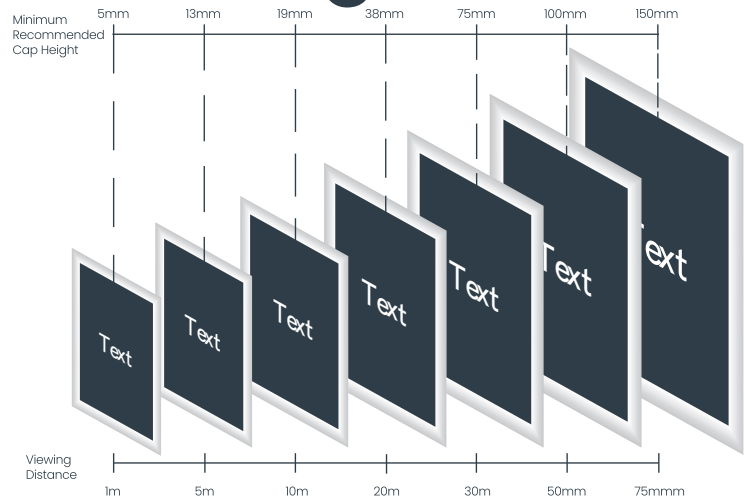

Index

A

A-Board.....	32
Accessories & Spares	198
Acrylic & ACM Wall Mounted Information Displays.....	154
Adfresco® Cafe Barrier Selection Tool.....	61
Adfresco® Example Layout.....	63
Adfresco® LT.....	59
Adfresco® Cafe Barrier.....	58
A-Master.....	13
A-Master Lite.....	14
A-Master Plus.....	15
Artwork tips.....	205

B

Banners.....	86
Banner Frame.....	46
Bar Runners.....	181
Base Plate for Flying Banners.....	56
Basket Liners.....	136
Basket Showcard Holders.....	113
Best Buy LEDbox.....	146
Bollard Wraps.....	47
Booster.....	17
Booster RAL Colours.....	17
Bracket Mount Bearing Spindles for Flying Banners.....	55
Brand Blocks.....	182
Brochure Display Units.....	127
Brochure Island Stands.....	130
Budget A-Board.....	33
Budget Banner Connectors.....	121
Budget Roll-Up Banner.....	120

C

Cable Suspended Snapframes.....	163
Chalk A-Boards by Woodworkz®.....	44
Chalkboards (Framed) - Indoor.....	150
Chalkboards (Framed) - Outdoor.....	95
Chalkboards (Unframed).....	94
Chalk Insert Panels.....	41
Classic Garden Parasol.....	64
Clear Menu Holder.....	171
Colour Management.....	190

Concrete Base for Flying Banner.....	56
Contents.....	2
Conversion Table.....	206
Counter Mat.....	181
Counterstand Snapframes.....	172
Counter/Table/Shelf - Indoor.....	168
Counter/Table Top Chalkboards.....	179
Cross Base and Water Bag for Flying Banner.....	56
Curved Pop-Up.....	124
Custom shape Flange Signs.....	88
Cyclone 2.....	21

D

Dealer/Stockist Signs.....	70
Decorative Brochure Stand.....	128
Decorative Menuboard.....	109
Defender.....	25
Description Of Goods.....	209
Digital Printing.....	191
D-Light.....	147
Dumpbin (Free-Standing).....	136
Dumpbins (Counter Top).....	183
Dye-Sublimation.....	191

E

Easel by Woodworkz®.....	102
Ecoflex 2.....	28
Ecoflex 2 Totem & Ecoflextra Totem.....	31
Ecoflex Chalkboard Panels.....	30
Ecoflex Custom Shaped Panels.....	30
Ecoflex (range overview).....	26
Ecoflexlite.....	27
Ecoflextra.....	29
Eco Roll-Up Banner.....	119
Eco Swinger.....	8
Edgelit XT.....	145
Extension Cable.....	201
Exterior Leaflet Holders.....	96

F

Feather Flying Banner.....	51
Feature Floor Mat.....	137
Felt Showboard.....	144
Flange Signs.....	88
Flavour/Range Boards.....	71
Flying Banner Bearing Spindle.....	49
Flying Banner Flag Materials.....	50
Flying Banner Flag Pole Sleeves.....	50
Flying Banner Mounting Accessories.....	54
Flying Banners.....	48
Flying Banner Selection Tool.....	49
Flying Banner with Base Plate.....	116
Frameworkz Snapframe.....	78
Freelight Plus.....	164
Free-Standing/Floor Mounted - Indoor.....	100
Free-Standing/Floor Mounted - Outdoor (Indoor).....	4

G

Giant Pole.....	57
Grip-Action Bases.....	175
Grip Chalkers.....	178
Grip Talkers.....	174
Ground Spike for Flying Banners.....	55

H

Hard Trolley Case/Counter.....	125
Headliner.....	141
Headlinerlite.....	142
Hi-Light Menu Stand.....	111
Hi-Sight.....	84

I

Ice Cream Holders.....	185
Illuminated Slimlok Menu Case.....	81
Illuminated Totem.....	108
Info Board.....	106
Informer.....	16
Interior Leaflet Dispensers.....	152, 176
i-Stand.....	112

K

Key.....	3
----------	---

L

Liquid Chalk Pens.....	93
Lockable Snapframes.....	77
Lockable Weatherproof Smart LEDbox.....	83

M

Magnetic POS Flag Arm.....	166
Metal Display Card Holder.....	180
Metal Floor Display Stand.....	107
Minimus Snapframes.....	143
Mobiles.....	165
Modular Pole Display.....	132
Multi-Cup Display.....	186

N

Noscrewz Flag Kit.....	91
------------------------	----

O

Open/Closed Signs.....	140
Our Chalkboard Panels.....	93
Our Print Capabilities.....	190
Outdoor Poster Materials.....	204
Overture Menu Holder.....	170

P

Paper Sizes.....	206
Parasols.....	64
Pivot Grippers.....	187
Pole & Rope Barrier.....	104
Portland Menustand.....	110
Poster Clamp.....	162
Poster Hanger.....	160
Poster Pillar.....	105
Poster Snap.....	161
POW! Sign.....	38
Premier A-Board.....	42
Premier A-Board Frame.....	42
Printed Backlit Poster Films.....	194
Printed Posters.....	192
Print Product Overview.....	196
Print Services, Printed Posters and Printed Backlit Poster Films.....	188
Promo Counter Carry Bag.....	203
Promo Counters.....	126
Promo Stands.....	123

PVC Banner.....	86
-----------------	----

Q

Quick Banner.....	118
Quick Banner carry case.....	203

R

Rectangle Flying Banner.....	53
Rollsby.....	122

S

Screen Printing.....	191
Security Snapframes.....	76
Sentinel®.....	22
Sentinel® Banner.....	36
Showcard Stands.....	114
Sightmaster 3.....	18
Sign Covers.....	37
Sign Nav.....	148
Signtac® Self-Adhesive Floor Graphics.....	66
Slatted Chain Chalkboard.....	167
Slatted Magnetic Chalkboard.....	149
Slimlok Menu Case.....	80
Slimlok Noticeboard.....	82
Slimlok Poster Case.....	79
Snapframes (overview).....	72
Spacemaster.....	129
Spring Sign.....	20
Spring Sign Tactical Header.....	20
Standard Flag Kit.....	90
Standard Snapframes.....	73
Stand-Off Sign Fixings.....	98
Stand-Off Sign Fixings Guidance.....	99
Stickers, Labels & Window Graphics.....	97
Straight/Tilt Talkers.....	173
Sucker Flags.....	89
Suspended/Hanging - Indoor.....	159
Swinger 2.....	9
Swinger 3000.....	10
Swinger 4000.....	11

T

Tactical Header for Sentinel®.....	24
Tactical Header for Sightmaster 3.....	19

Tactical Header for Spring Sign.....	20
Tactical Header for Swinger.....	12
Tank Base for Flying Banner.....	54
Teardrop Flying Banner.....	52
Teardrop Flying Banner (on Angled Wall Bracket).....	92
Trolley and Hose.....	40

V

Varnish Over-Print.....	190
Viewing Distances.....	206

W

Wall Banner Frame.....	87
Wall Chalkboards (Unframed).....	94
Wall Mounted Information Displays.....	154
Wall-Mounted Literature Dispenser.....	151
Wall/Window Mounted - Indoor.....	139
Wall/Window Mounted - Outdoor (Indoor).....	69
Waterbase A-Board.....	34
Waterbase Pyramid.....	35
Wheel Base for Flying Banner.....	54
Wobbler.....	184
Woodworkz® Chalk A-Boards.....	44
Woodworkz® Easel.....	102
Woodworkz® Framed Chalkboards (Indoor).....	150
Woodworkz® Framed Chalkboards (Outdoor).....	95

X

X-Banner.....	117
---------------	-----

Description of Goods

Before using any of these products, the customer shall determine the suitability of the product for its intended use, and the customer assumes all risks and liability whatsoever in connection herewith. The supplier shall not be liable either in tort or in contract for any loss or damage – direct, incidental or consequential, arising out of the use of, or the inability to use any of the products

All specifications, drawings, illustrations, particulars of weight and dimensions issued are approximate only and do not form part of any terms, conditions or warranties of any contract. The supplier may vary such specifications, drawings, illustrations, particulars of weight and dimensions at any time and for whatever reason, without having to give a reason or explanation.



**SIGN
& DISPLAY**
COLLECTION

